

CARACTERISTICAS

MATERIAL hormigón armado
 COLOR gris granítico
 ACABADO decapado e hidrofugado
 COLOCACION apoyado sin anclaje
 PESO 1100 kg

MATERIAL reinforced cast stone
 COLOUR granite grey
 FINISH acid-etched and waterproofed
 FIXING free-standing
 WEIGHT 1100 kg

DISEÑO / DESIGN Cruz y Ortiz Arquitectos

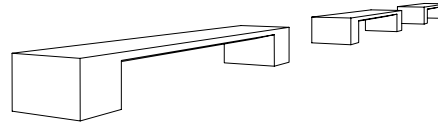

ABRIL®

SISTEMA DE COLOCACION

GEOMETRIA

ESCALA 0 CM 50 CM

elevación / hoisting
 (P=1100 Kg.)

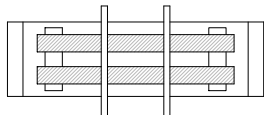

Planta cenital
 / View from above

Descarga con carretilla elevadora:

Colocar una base de tablonés según el gráfico, a fin de elevar el banco dejando 2m de luz entre apoyos

Unloading by fork-lift:

Lift bench by interposing wooden boards that support bench by means of two rests placed at 2 m distance from each other.

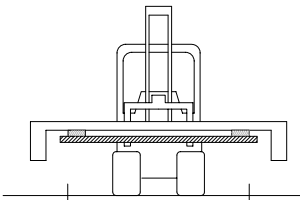

Alzado / Side view

Descarga con grua:

Colocar las bridas de forma que la luz entre ellas sea aprox. 2m.

Unloading by crane

Place slings so as distance between suspension points be at least of 2 m.

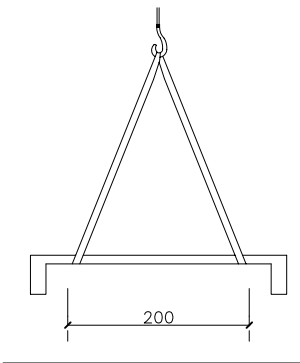

Alzado / Side view

BANCO APOYADO SIN ANCLAJE

FREE-STANDING BENCH

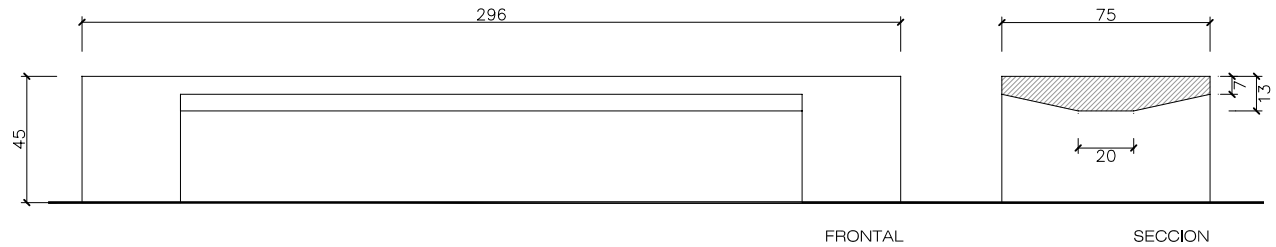

FRONTAL

SECCION

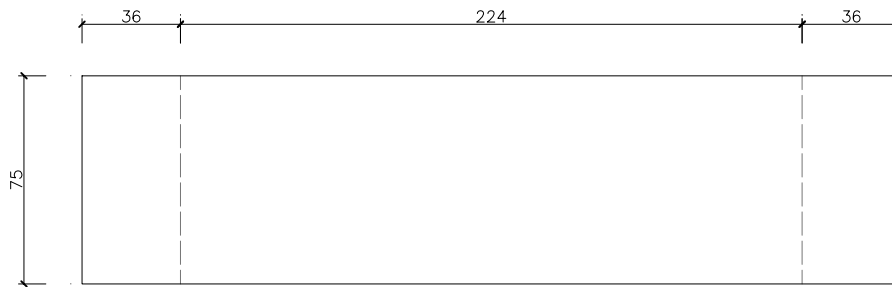

PLANTA