

CARACTERISTICAS

MATERIAL hormigón UHPC
 COLOR carta de colores estándar
 ACABADO decapado e hidrofugado pulido suave (*)
 COLOCACION anclado con tornillos
 PESO 132 kg / 275 kg
 537 kg / 596 kg

MATERIAL UHPC concrete
 COLOUR standard colour chart
 FINISH etched and waterproofed soft polished (*)
 FIXING anchored with screws
 WEIGHT 132 kg / 275 kg
 537 kg / 596 kg

DISEÑO / DESIGN Equipo Técnico Escofet

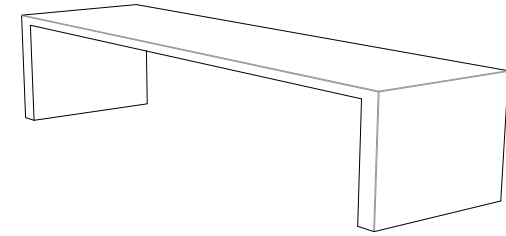

SISTEMA DE COLOCACION

elevación / hoisting
(P=537 kg)

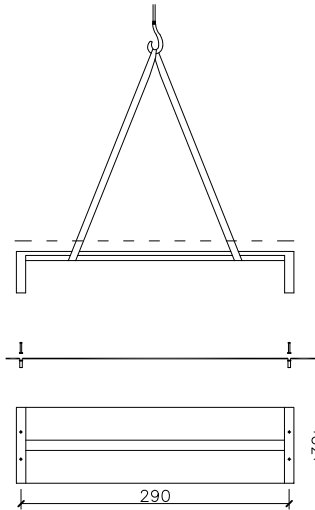

elevación / hoisting
(P=275 kg)

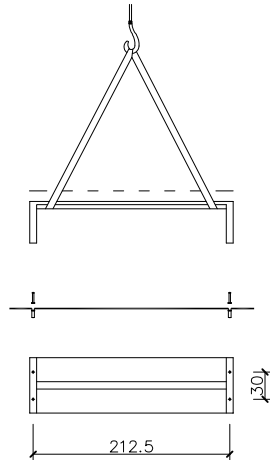

(*) El acabado pulido suave se aplica sólo en la superficie superior (véase línea discontinua).
 The soft polished finish is only applied on the upper surface (see dashed line).

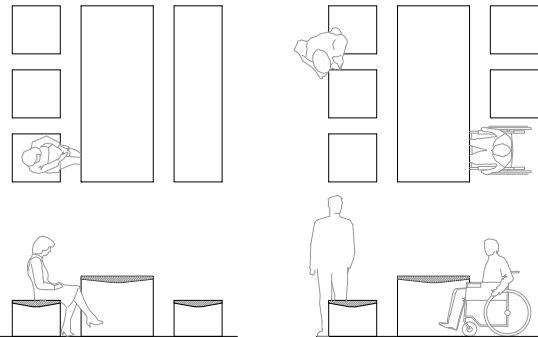

GEOMETRIA

ESCALA 0 CM 50 CM

