

The *Test-e* planter is made of dry-mix concrete, and supplied in two lengths: 2 metres and 1.20 metres. It has a striking oval shape, sharpened at each end to lighten its presence. Its texture includes linear diagonal grooves that reduce the apparent weight of the concrete while at the same time acting as a transition to the verticality of the plants growing inside it. The aligned arrangement of several planters acts as a vegetated boundary between roads and pavements, eliminating the need for bollards or pivots.

Concrete | 200 cm |  370 kg |  113 L

 Update 03.08.2020



Origin

Assuming this dual function, the architects designed *Test-e* in conjunction with *Escofet* in 1988, with the intention of installing it on pavement edges in the Eixample district of Barcelona. This street furnishing element is part of the A-E-I-O-U Vocabulary Collection, composed of *Test-e*, *Llum-i Gat-o* and *Banc-u*. The hint embedded in their compound names implicitly contains the idea of creating a new vocabulary of elements as the expression of the specific response of each one to the same issue: the confrontation between the neutral gravity of fluid concrete and the potential tension it adopts when adapting to different uses.

Material

Moulded concrete, reinforced with stainless steel, with a stripped finish and in the *Escofet* standard chart colour.

Installation

Self-stabilising, no anchors are required to install them. Drainage takes place through the holes that pass through the baseboard at the bottom.





Test-e narrows on the plan until it loses the sense of a dimension, marking the space like a small filled with plants and flowers.



1. Planter

Test-e	200	120
Dimensions	200 x 40 x 53 cm	120 x 32 x 42 cm
Weight	370 kg	174 kg
Capacity	113 L	35 L

1.1 General features

Material	Reinforced concrete	Fixing	Free-standing
Finish	Etched and waterproofed		

Colours



GR. Grey



BL. White

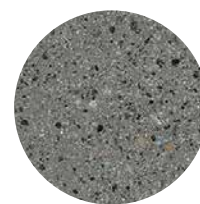

CA. CA Grey

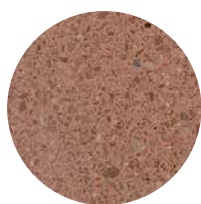

RA. Red

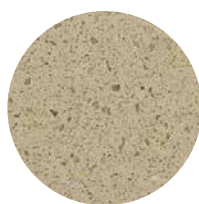

BG. Beige

1.2 Installation system

Hoisting

(W= 370 / 174 kg)

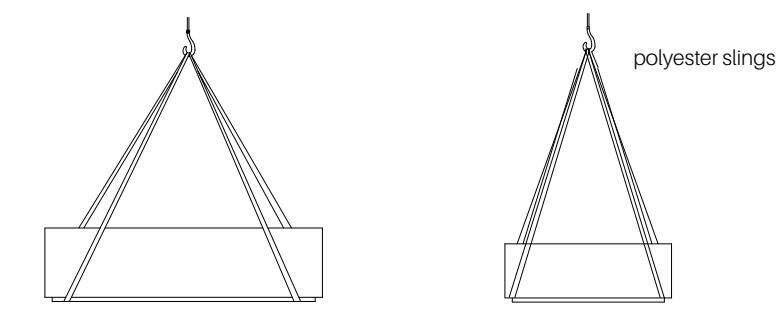

1.3 Geometry

Test-e 200

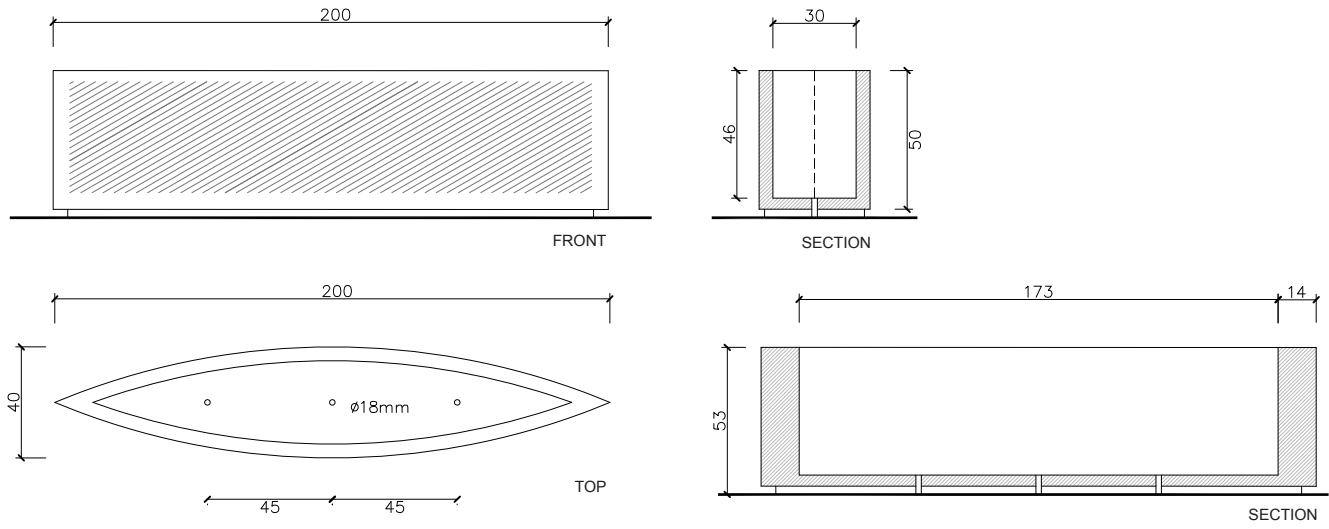

Test-e 120

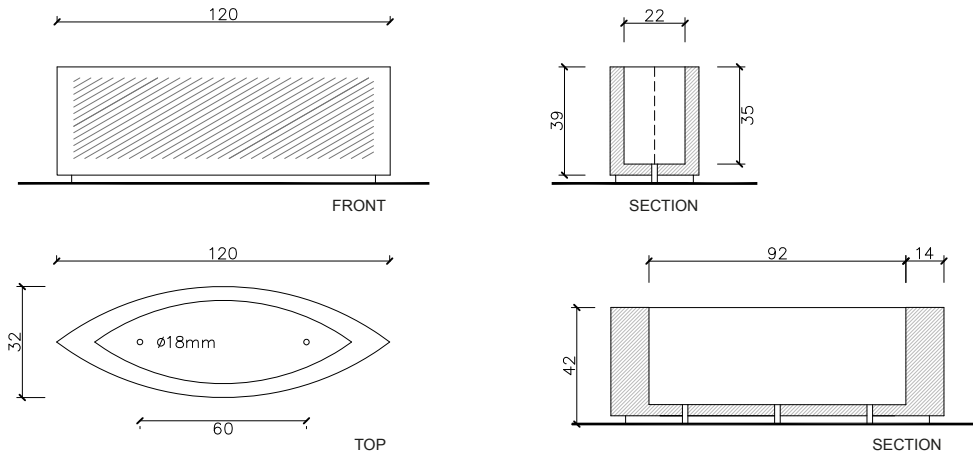



Warranty

5 years in all its components.

The names, trademarks and industrial models of the products have been logged in the corresponding registers. The technical information provided by Escofet about its products can be modified without prior notice.

Escofet 1886 S.A
Head office and production

Montserrat, 162
E 08760 Martorell
Barcelona - España
T. 0034 937 737 150
F. 0034 937 737 151

info@escofet.com
www.escofet.com



GA-2005/0072 SST-0090/2010 ER-0403/2016