

CARACTERISTICAS

MATERIAL hormigón armado
 COLOR blanco / negro
 ACABADO decapado e hidrofugado
 COLOCACION anclado con tornillos
 PESO 155 kg
 CAPACIDAD 40 litros
 PALET 100 x 100 / 4 uds
 BOLSA PLÁSTICO 70 L / 575 x 1000 mm

MATERIAL reinforced cast stone
 COLOUR white/black
 FINISH acid-etched and waterproofed
 FIXING anchored with screws
 WEIGHT 155 kg
 CAPACITY 40 litres
 PALLET 100x 100 / 4 units
 PLASTIC BAG 70L / 575 X 1000 mm

DISEÑO / DESIGN Diego Fortunato

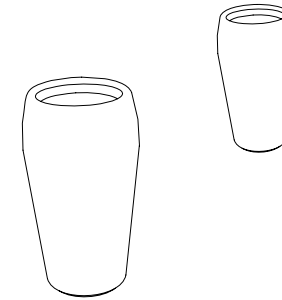

SISTEMA DE COLOCACION

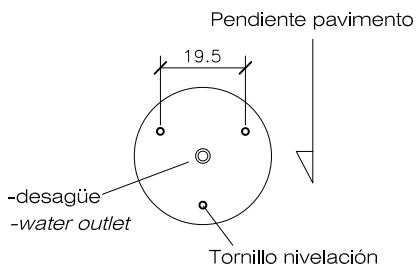
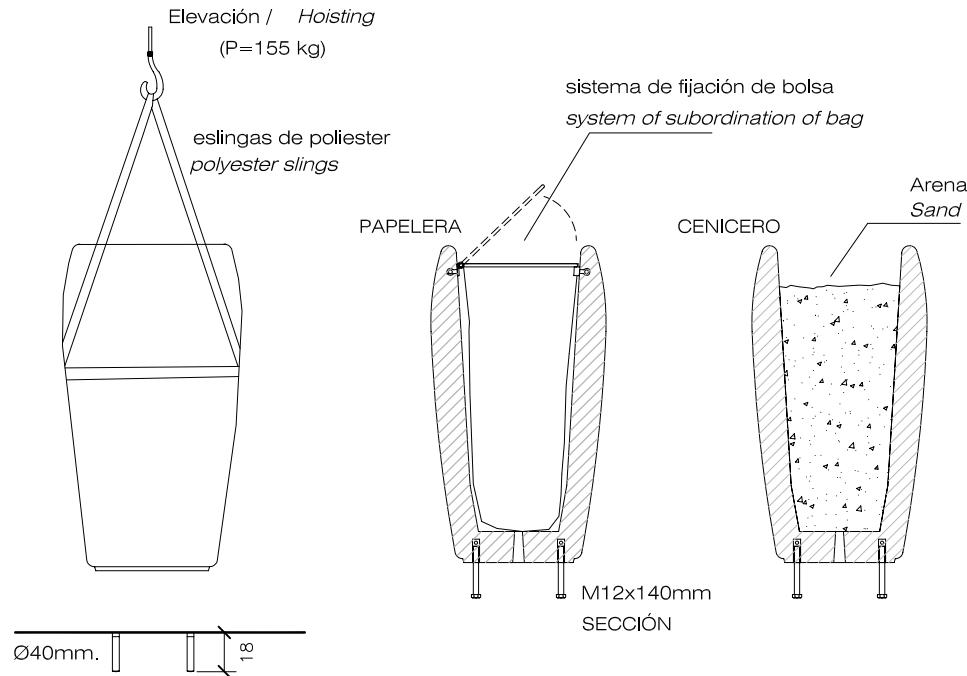

- Roscar los 2 tornillos a fondo M-12x140
 -Tightly screw the 2 stud bolts M-12x140
- Taladrar el pavimento (Ø40x180) y llenar con resina o mortero rico.
 -Drill pavement (Ø40x180) and fill with resin or fat mortar
- Centrar y colocar
 -Centre and caulk

GEOMETRIA

ESCALA 0 CM 25CM

