

Juanola is a moulded concrete element with a rhomboid shape, designed as a mobile element to separate pedestrian and traffic areas, and also for use as an occasional seat. The autonomy of its geometry facilitates the variable separation between the pieces and permits the graduation of the different enclosing and protective levels within the urban space it delimits.

Concrete | 📏 175 cm | ⚖️ 370 kg | 🚚 2

🔄 Update 24.08.2020

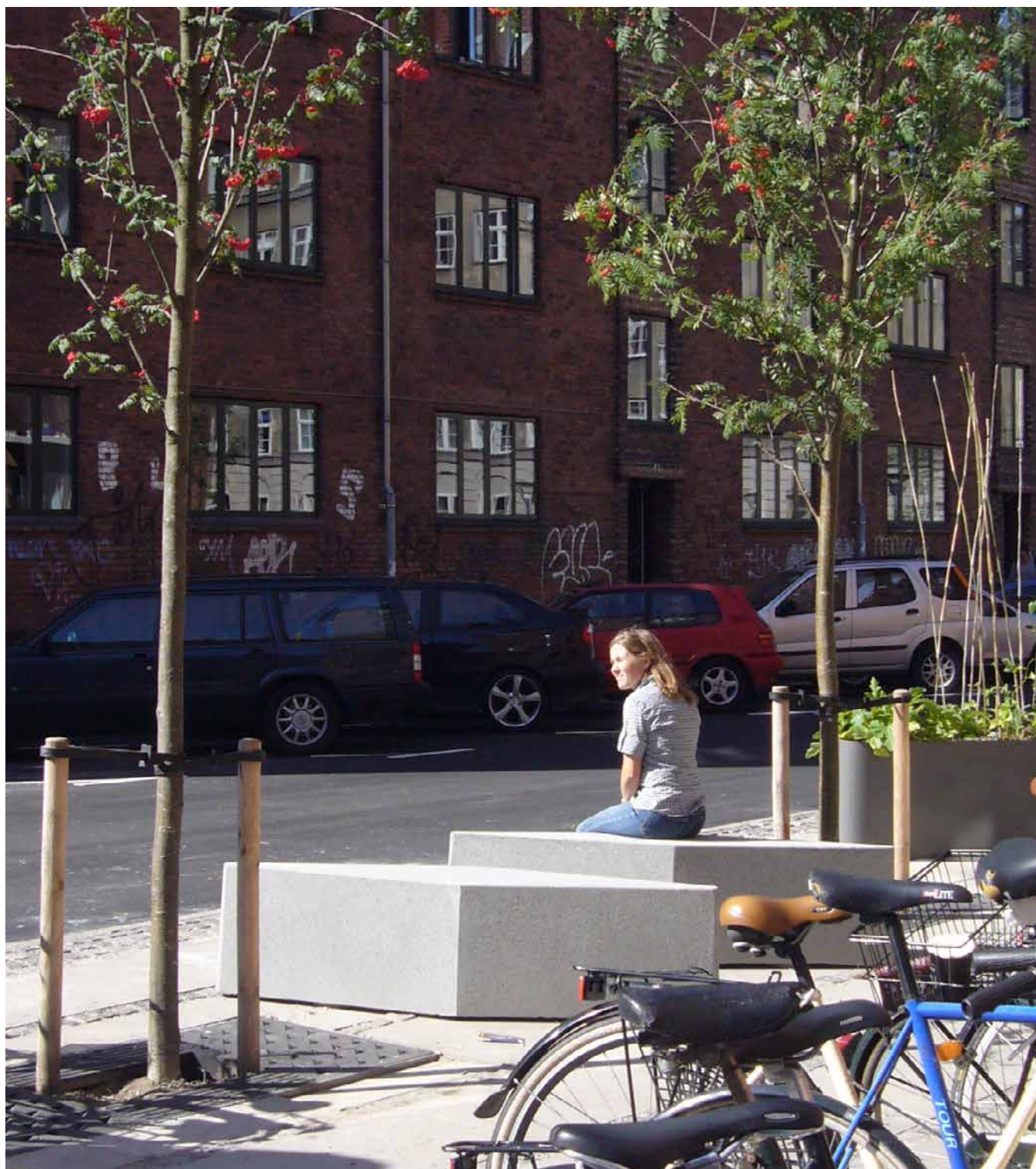

Origin

It takes its name from the direct rhomboid homothetic transformation of the Juanola cough drops that were first produced in 1906 by the pharmacist Manuel Juanola Reixach. Since then, Juanola has become an emblematic brand that forms part of the personal memory of several local generations.

Versatile

Due to its particular geometry, the model adapts perfectly to multiple arrangements with differing grades of opacity. From individual uses as bollards, to overlapping arrangements as boundary walls and seats.

Material

Non-reinforced moulded concrete with an etched finish, in the Escofet catalogue standard chart colours.

Installation

Due to its heavy weight and low centre of gravity, it rests on the ground, with no need for anchors. Its two support points ensure its stability and permit the passage of slings for frequent lifting and moving operations.



JUANOLA



Escofet[®]

1. Backless bench and limit

Juanola

Dimensions 175 x 40 x 47 cm

Weight 370 kg

1.1 General features

Material Concrete **Fixing** Free-standing

Finish Etched and waterproofed

Colours



GR. Grey



BL. White

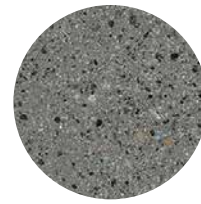

CA. CA Grey

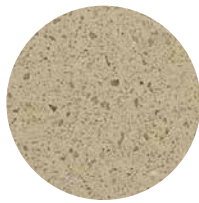

BG. Beige

1.2 Installation system

Hoisting
(W= 370 kg)

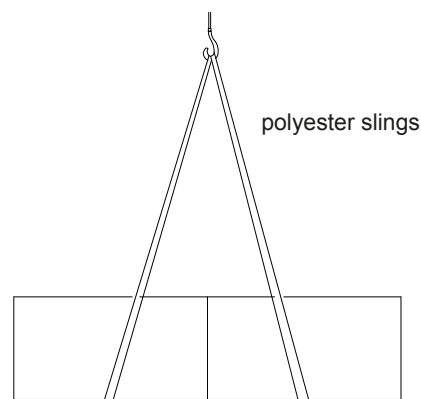

Juanola

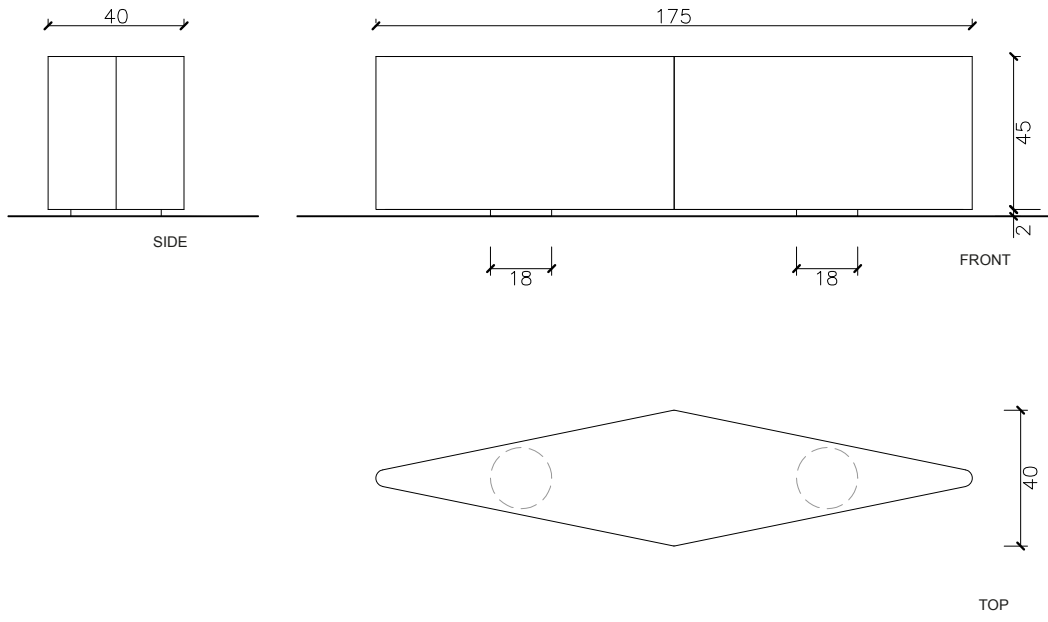

Example of placement

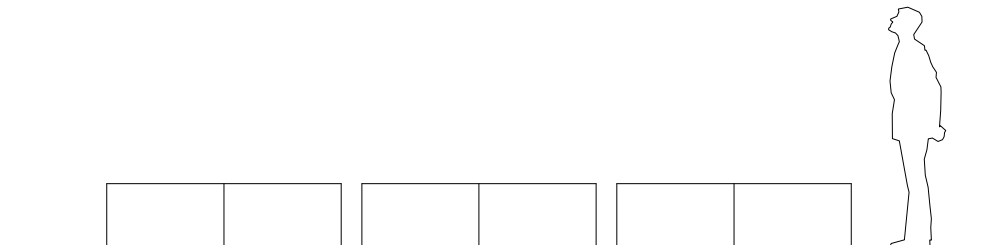
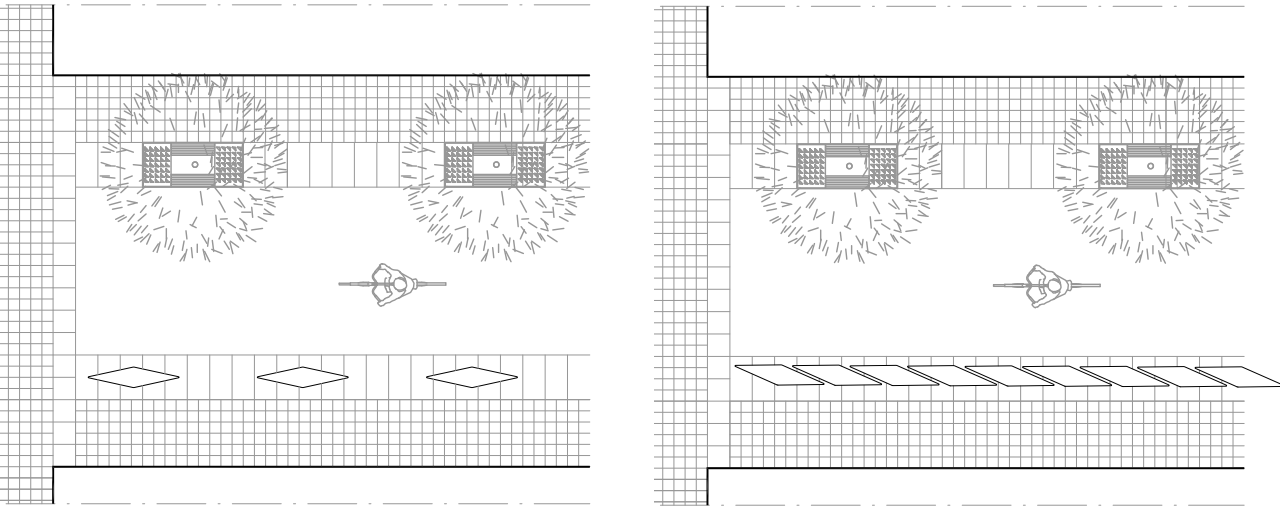



Warranty

5 years in all its components.

The names, trademarks and industrial models of the products have been logged in the corresponding registers. The technical information provided by Escofet about its products can be modified without prior notice.

Escofet 1886 S.A
Head office and production

Montserrat, 162
E 08760 Martorell
Barcelona - España
T. 0034 937 737 150
F. 0034 937 737 151

info@escofet.com
www.escofet.com



GA-2005/0072 SST-0090/2010 ER-0403/2016