

CARACTERISTICAS

MATERIAL hormigón
 COLOR carta colores estándar
 ACABADO decapado e hidrofugado
 COLOCACION anclado con tornillos
 PESO 225 kg

MATERIAL *cast stone*
 COLOUR *standard color chart*
 FINISH *etched and waterproofed*
 FIXING *anchored with screws*
 WEIGHT *225 kg*

DISEÑO / DESIGN IAUC

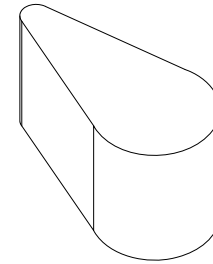

SISTEMA DE COLOCACION

- Roscar los 2 tornillos a fondo M-16x140
 - *Tightly screw the 2 stud bolts M-16x140*
- Taladrar el pavimento (Ø40x180)
 y llenar con resina o mortero rico
 - *Drill pavement (Ø40x180) and fill with resin or fat mortar*
- Centrar y colocar
 - *Centre and caulk*

elevación / *hoisting*
 (P= 225 kg)

2 eslingas de poliéster
 2 *polyester slings*

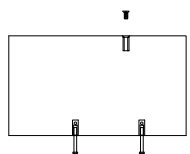
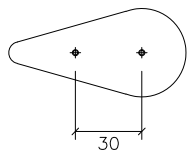
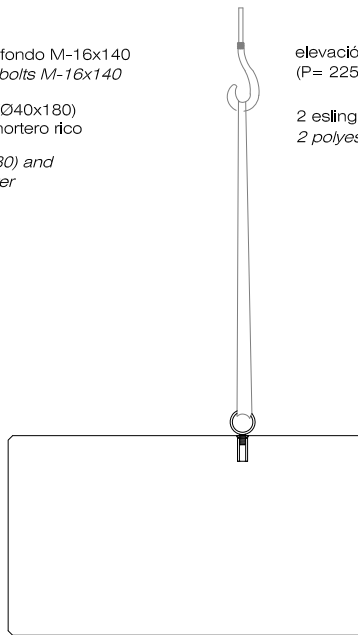

M-16 x 140

Ø40 x 180

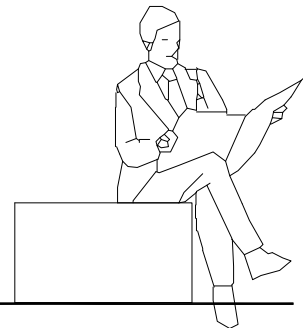

GEOMETRIA

ESCALA 0 CM 50 CM

