

CARACTERISTICAS

MATERIAL hormigón
 COLOR carta colores estándar
 ACABADO decapado e hidrofugado
 MATERIAL polietileno HDPE
 COLOR standard color chart
 COLOCACION anclado con tornillos
 PESO 350 kg
 CAPACIDAD 70 litros
 PALET 70 x 70

MATERIAL concrete
 COLOUR standard color chart
 FINISH etched and waterproofed
 MATERIAL polyethylene HDPE
 COLOUR standard color chart
 FIXING anchored with screws
 WEIGHT 350 kg
 CAPACITY 70 litres
 PALLET 70 x 70
 DISEÑO / DESIGN Salvador Fabregas

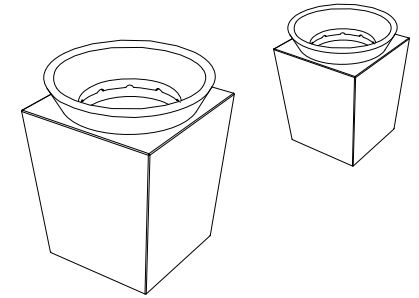

SISTEMA DE COLOCACION

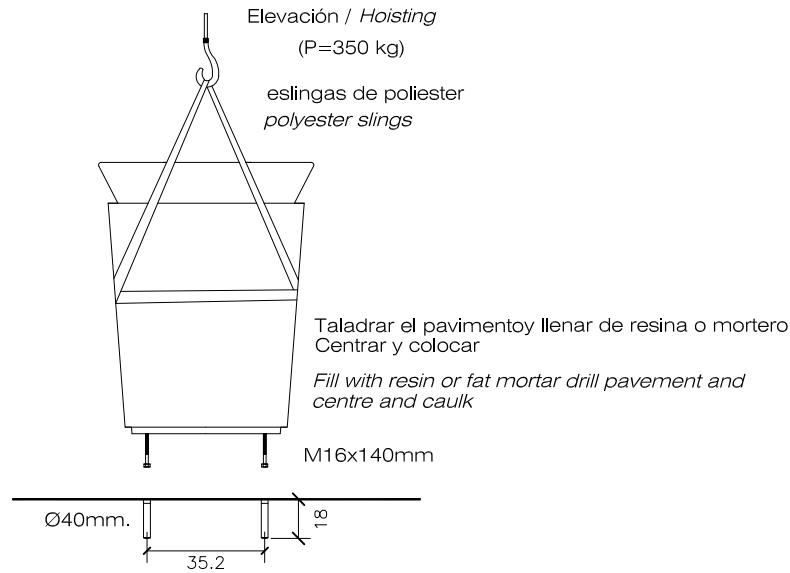

sistema de fijación de bolsa
system of subordination of bag

Aro acero inoxidable Ø8mm.
Stainless steel ring Ø8mm

cable acero inoxidable
Stainless steel cable

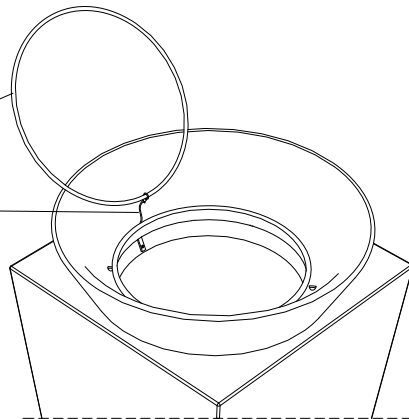

GEOMETRIA

ESCALA 0 CM 50 CM

