

CARACTERÍSTICAS / CHARACTERISTICS

MATERIAL hormigón
 COLOR carta de colores estándar
 ACABADO decapado e hidrofugado
 COLOC. apoyado sin anclaje
 PESO 1750kg / 1900kg

MATERIAL concrete
 COLOUR standard colour chart
 FINISH etched and waterproofed
 FIXING free-standing
 WEIGHT 1750kg / 1900kg

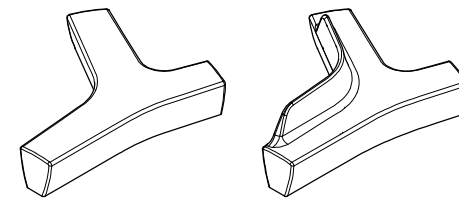

TWIG

Update 29/07/2021
 Cotas / Sizes cm

INSTALACIÓN / INSTALLATION

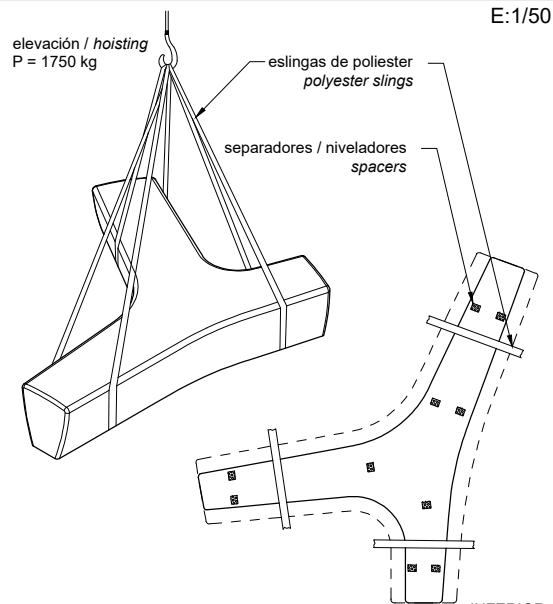

E:1/50

situar 10 separadores en el suelo para manejar eslingas correctamente
 place 10 spacers on ground so slings can be managed correctly

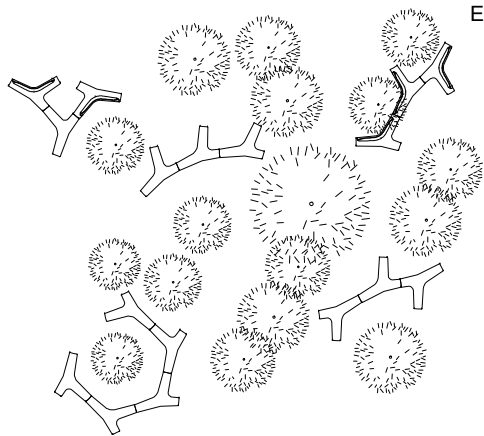

E:1/400

en agregación usar separadores de nylon entre piezas
 use nylon spacers in aggregation between pieces

GEOMETRÍA / GEOMETRY

TWIG

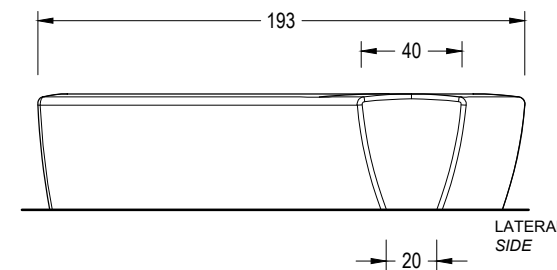
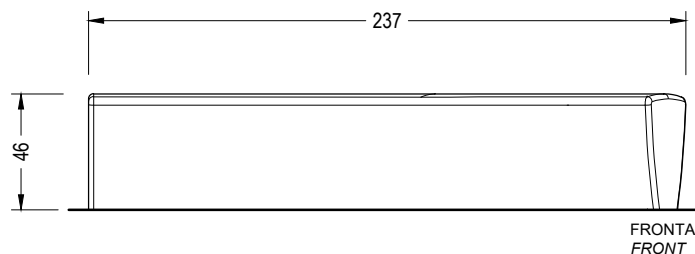

E:1/30

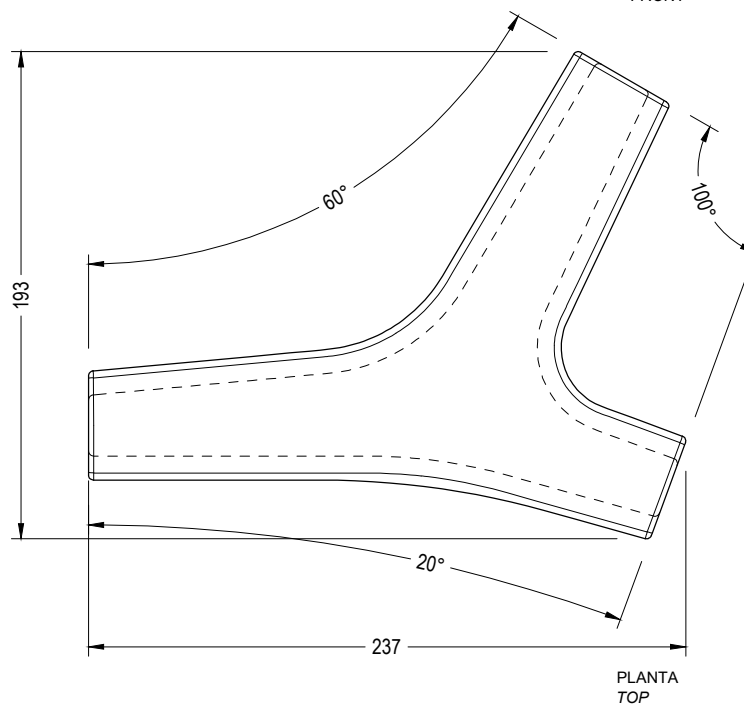

Alexander Loterstain

escofet®

CARACTERÍSTICAS / CHARACTERISTICS

MATERIAL hormigón
 COLOR carta de colores estándar
 ACABADO decapado e hidrofugado
 COLOC. apoyado sin anclaje
 PESO 1750kg / 1900kg

MATERIAL concrete
 COLOUR standard colour chart
 FINISH etched and waterproofed
 FIXING free-standing
 WEIGHT 1750kg / 1900kg

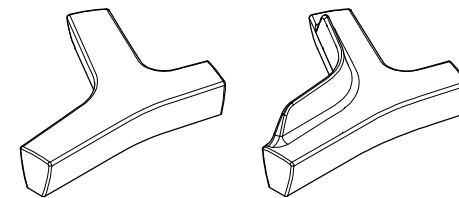

TWIG

Update 29/07/2021
 Cotas / Sizes cm

INSTALACIÓN / INSTALLATION

GEOMETRÍA / GEOMETRY

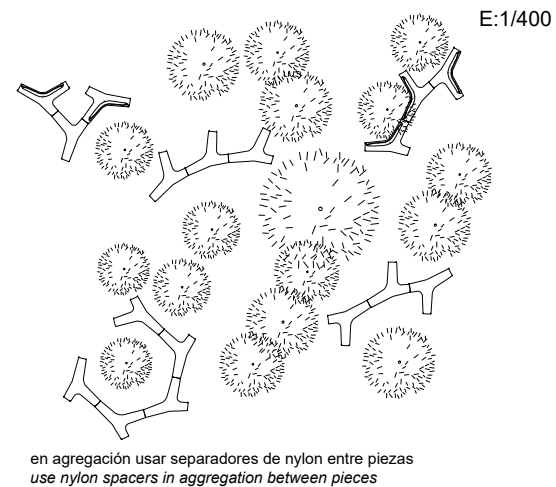
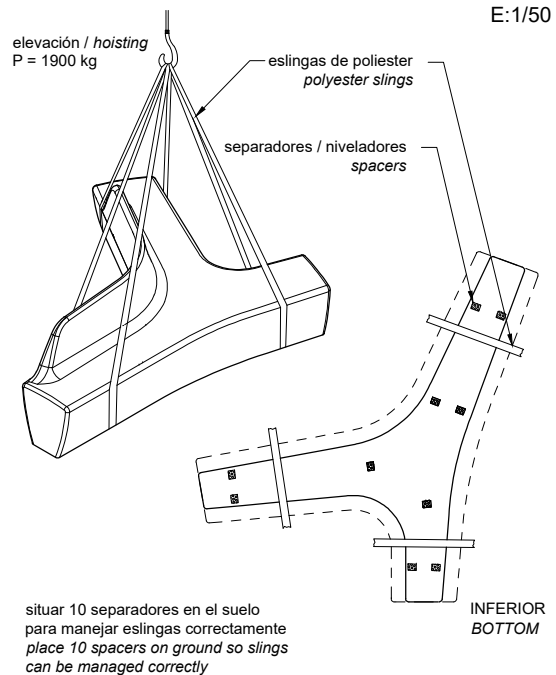

TWIG respaldo / backrest

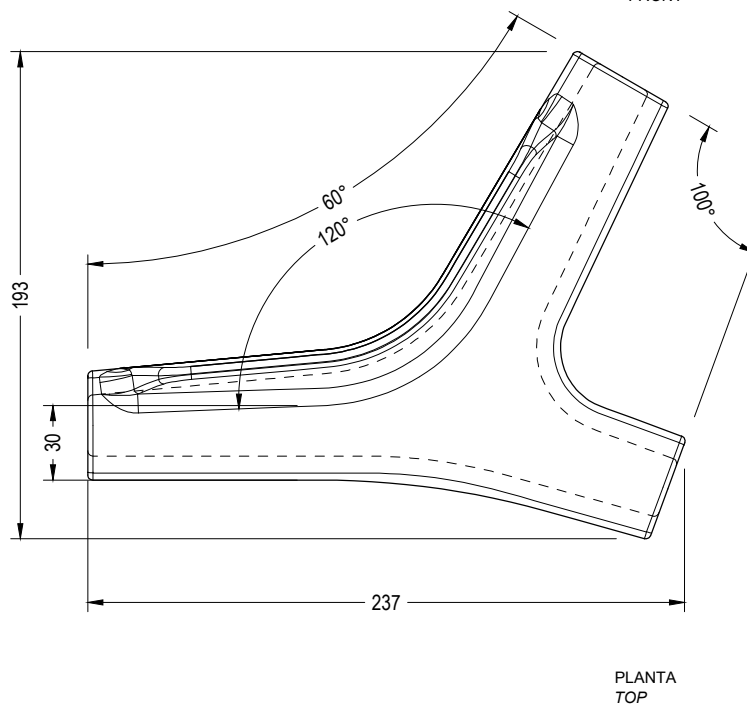
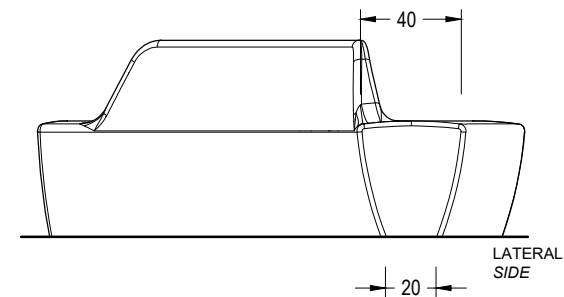
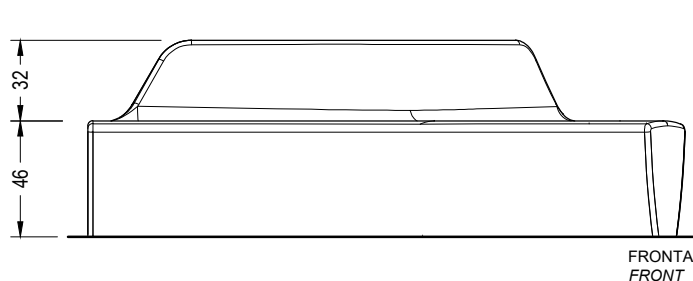

E:1/30

Alexander Loterstain

escofet®