

Net Planter is a reinforced concrete planter in clear reference to the traditional ceramic vessels, with the formal characteristics similar to the *Net* bin, the original element of the collection. Its friendly and rounded shapes facilitate its integration in any environment, both exterior and interior. Its installation can be in isolation or in combination with the bin-ashtray of the same collection.

Concrete | Ø 71 cm | ⚖ 330 kg | 🪴 120 L

🔄 Update 17.03.2022



Origin

Net Planter emerges as a review of the design of the *Net* ash tray with the objective of creating a moderate volume planter, suitable for medium-sized plants, with a capacity of 120 liters.

Material

Monomaterial body of concrete reinforced with stainless steel. Soft etched and water-repellent finish. Supplied in the all *Escofet* standard chart colours.

Installation

Concealed installation by means of three threaded Din 931 M16 x 140 mm bolts with a rustproof protective finish in holes previously drilled in the paving and filled with epoxy resin or rich mortar. Drainage by central hole of 3 cm. diameter.

NET PLANTER



Escofet®

NET PLANTER



1. Planter

Net Planter

Dimensions Ø 71 x 82 cm

Weight 330 kg

Capacity 120 L

1.1 General features

Material Reinforced concrete **Fixing** Anchored with screws

Finish Etched and waterproofed

Colours



GR. Grey

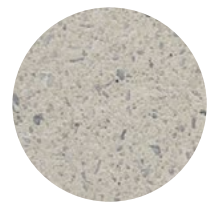

BL. White



CA. CA Grey

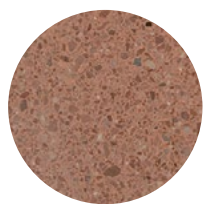

RA. Red

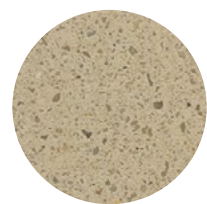

BG. Beige

1.2 Installation system

Hoisting
(W= 330 kg / with soil P=535 kg)

Installation
Tightly screw the 3 stud bolts M16 x 140.
Drill pavement (Ø40 x 180 mm)
and fill with resin or fat mortar.
Centre and caulk.

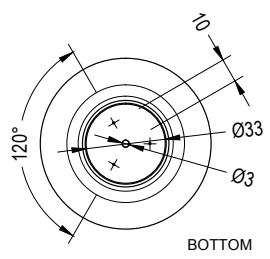
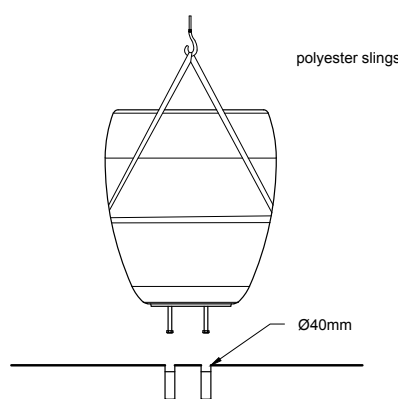

Net Planter

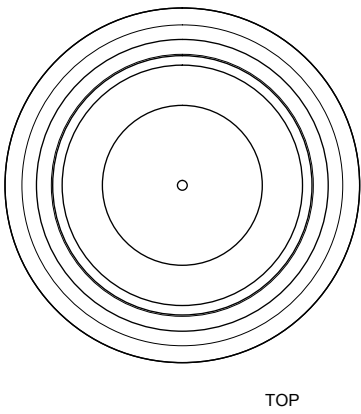
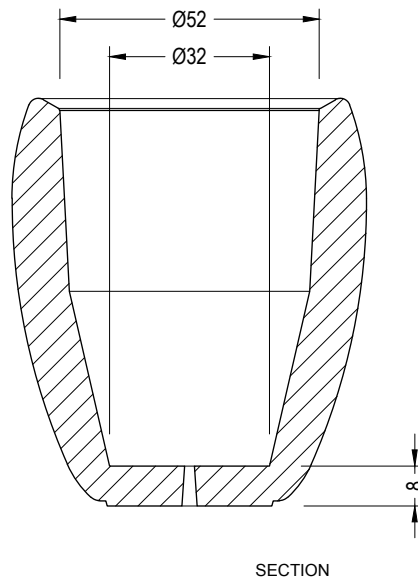
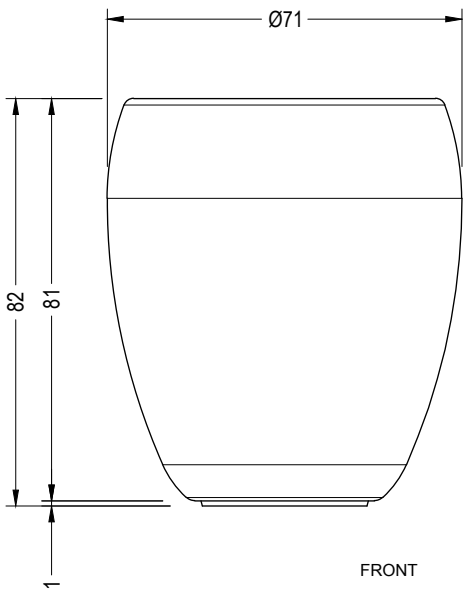

Aggregation with Net

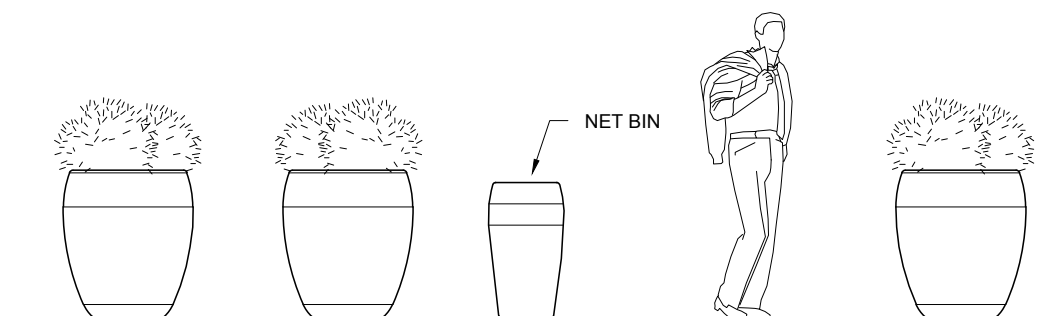



Warranty

5 years in concrete elements.

The names, trademarks and industrial models of the products have been logged in the corresponding registers. The technical information provided by Escofet about its products can be modified without prior notice.

Escofet 1886 S.A
Head office and production

Montserrat, 162
E 08760 Martorell
Barcelona - España
T. 0034 937 737 150
F. 0034 937 737 151

info@escofet.com
www.escofet.com

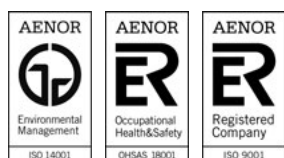

GA-2005/0072 SST-0090/2010 ER-0403/2016