

SERP is a modular backless bench system formed by eight models with different radii, some of them with backrest option, which can be added to others to form long zigzag bench arrangements, with and without LED lighting. Its rounded ends permit the installation of continuity modules, with no specific requirements in terms of precision. In the SERP Comfort version, the modules have a recessed teak wood seat.

Concrete | Modular | 243 cm/max | 1520 kg | 4

Add-ons: | LED

Update 06.05.2026



ORIGIN

The concept of the modular bench Serp was born as a response to the unique demands of the landscape project. The Comfort accessory was installed for the first time in the elevated plaza of the Diagonal Mar shopping mall in Barcelona, where LED lighting was also incorporated for the first time into the standard grooves designed for this purpose. In the surroundings of Torre Sevilla, a version with a backrest was developed, designed to provide protection from the wind.

MODULAR

Different aggregations to the backless bench system permit the creation of straight or undulated continuous backless benches. Accessibility is enhanced through the backrest option, either in concrete or through metal accessories adapted to each module. A metal armrest can also be incorporated. It can also be used to retain earth and form a boundary between areas with plants and areas frequented by pedestrians.

MATERIAL

The modules, with a square cross section of 50 x 50 cm and gently rounded edges, are made from dry mix concrete with an etched and water-repellent finish, in the Escofet standard chart colours. Optional accessories, including backrests and armrests, are made of zinc-coated steel and finished in a textured silver color.

INSTALLATION

Due to its heavy weight, it rests subtly on the ground or paving, with no need for anchors. Each module has two supporting legs that permit the passage of transportation slings to lift it from the ground, thus facilitating rain-water drainage.



SERP

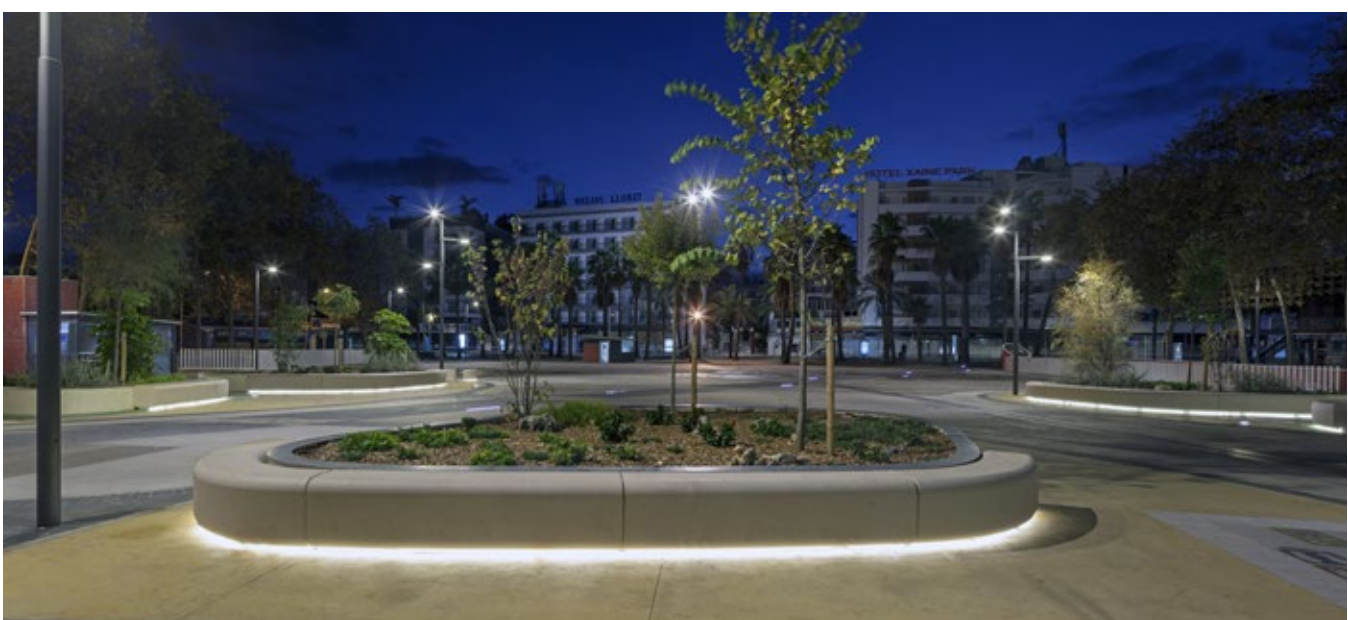

Escofet
by Molins[®]

1. Modular backless benches

Serp	R100	R150	R185	R400	R1185
Dimensions	243x92x54 cm	199x70x54 cm	223x72x54 cm	200x60x54 cm	253x56x54 cm
Weight	1430 kg	1094 kg	1244 kg	1140 kg	1486 kg
Lighting	LED strip 8-15W/m 4000°K / 3000°K				
Driver	24 V / 1,5A / IP67				

Serp	R1915	Recto	R600 Backrest	R600 L	R600 R
Dimensions	224x54x54 cm	225x50x54 cm	211x82x115 cm	207x79x115 cm	207x79x115 cm
Weight	1327 kg	1345 kg	2088 kg	1580 kg	1580 kg

Serp	Recto Backrest	Losa Transition	Losa Recto	Losa R150 60°	Losa R150 45°
Dimensions	220x75x115 cm	225x50x60 cm	150x50x16 cm	199x70x16 cm	152x61x16 cm
Weight	2262 kg	1055 kg	258 kg	317 kg	235 kg

1.1 General features

Material	Concrete	Fixing	Free-standing
Finish	Etched and waterproofed		
Seat	Teak Wood		

Colours

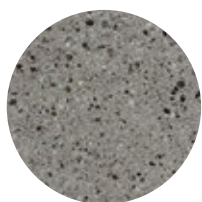

GR. Grey

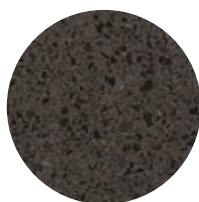

NG. Black

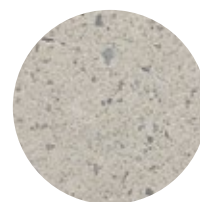

BL. White

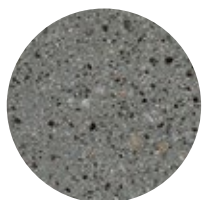

CA. Grey CA

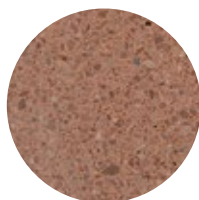

RA. Red

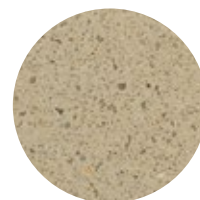

BG. Beige



A. Teak

1.2 Installation system

Hoisting

(W= 1430 kg / 1094 kg / 1244 kg / 1140 kg / 1486 kg / 1327 kg / 1345 kg / 2088 kg / 1580 kg / 1580 kg / 2262 kg / 1055 kg)

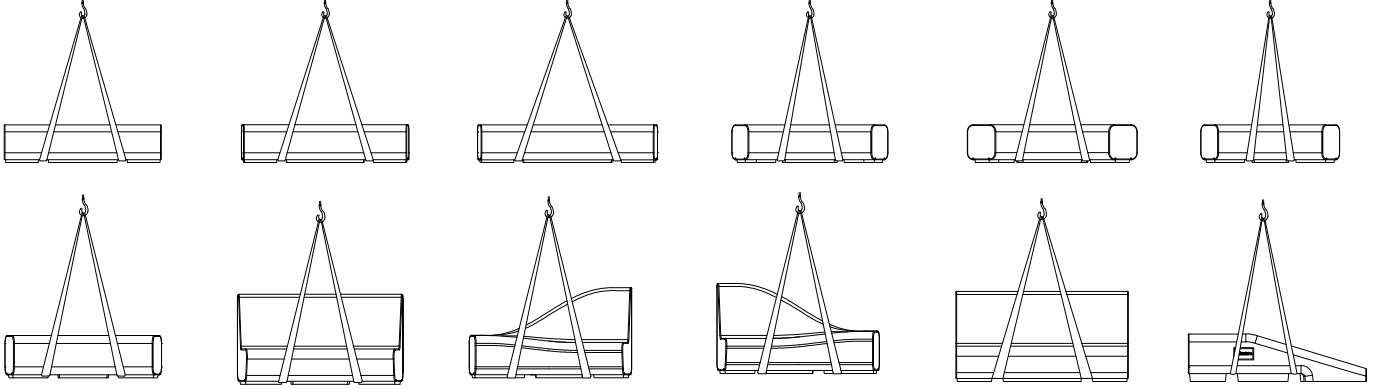

1.3 Geometry Serp R100

Serp R100

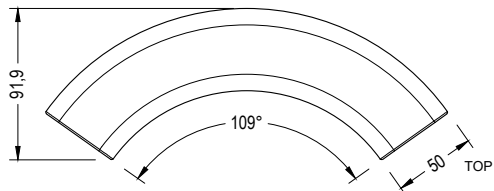
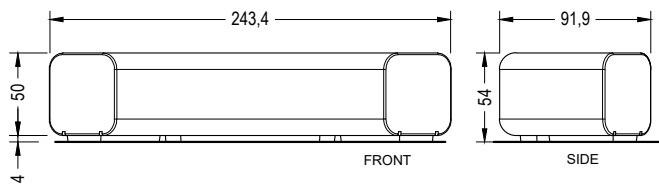

Serp Comfort R100

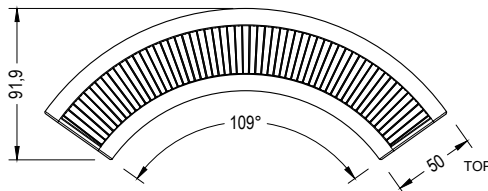
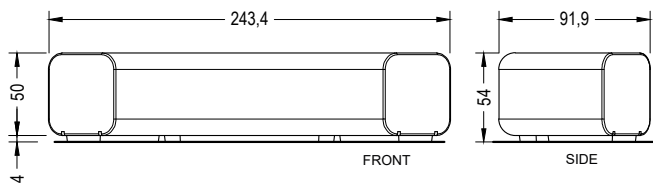

Serp R100 LED

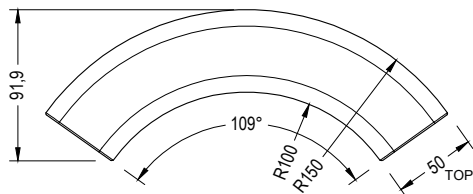
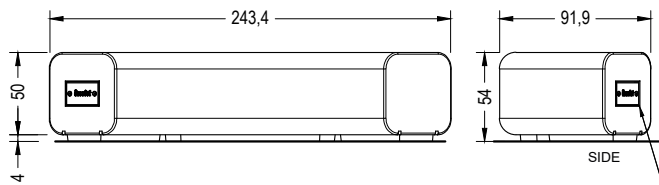
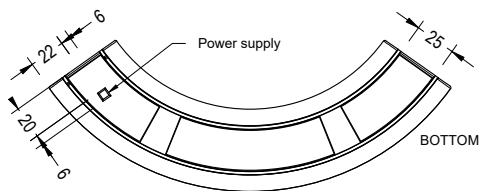

Serp Comfort R100 LED

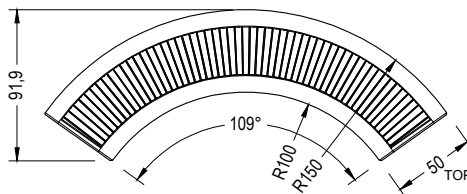
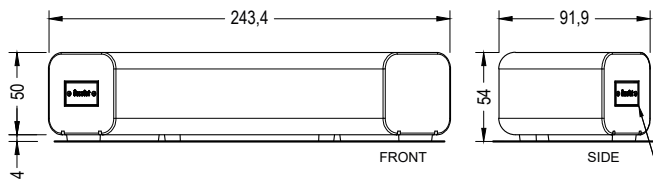
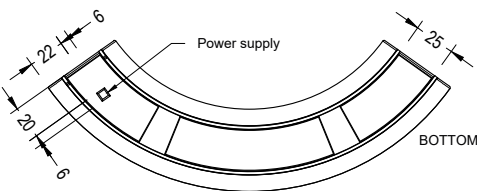

Concrete inspection hatch available on both sides

Concrete inspection hatch available on

1.3 Geometry Serp R150

Serp R150

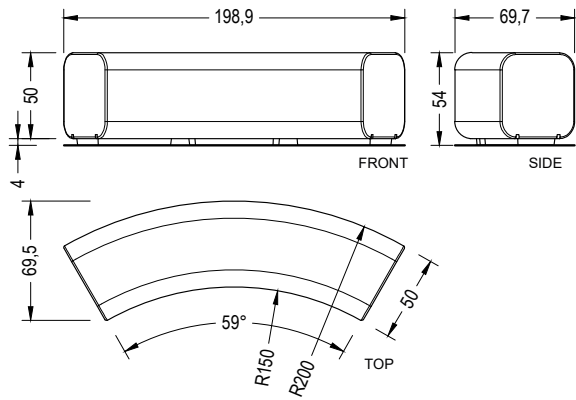

Serp Comfort R150

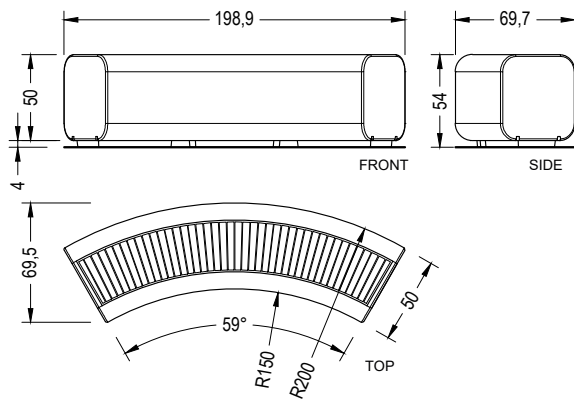

Serp R150 LED

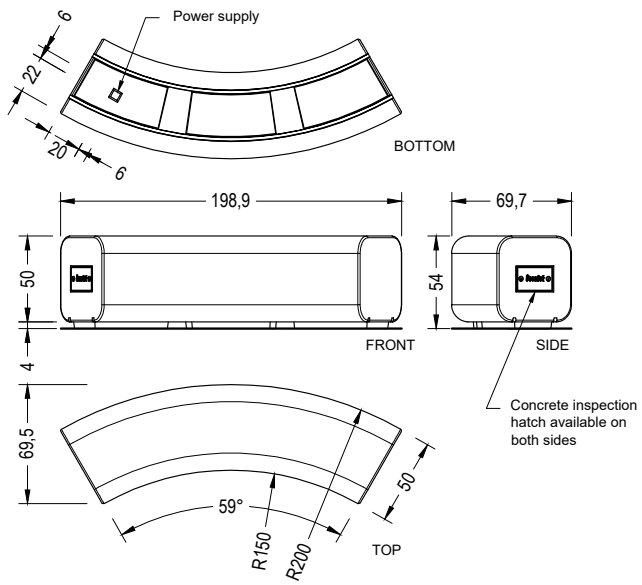

Serp Comfort R150 LED

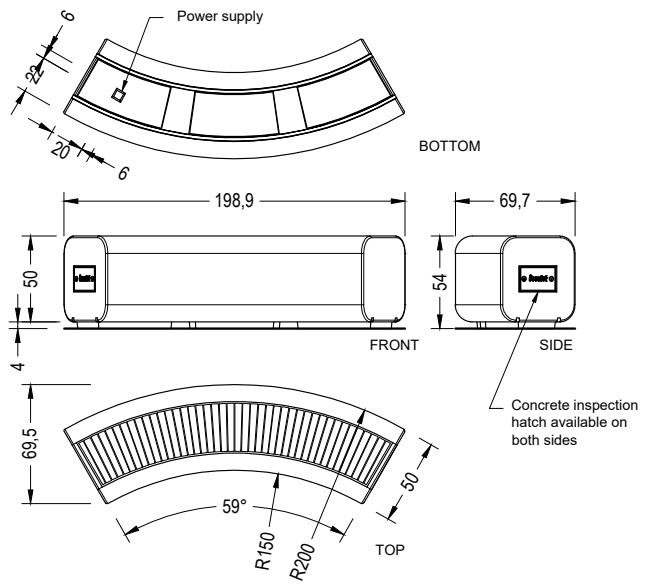

1.3 Geometry Serp R185

Serp R185

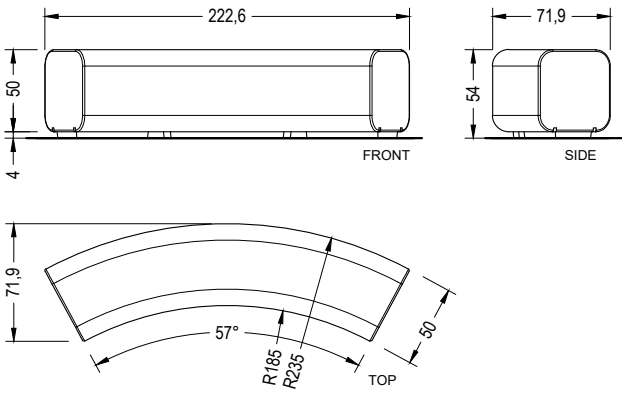

Serp Comfort R185

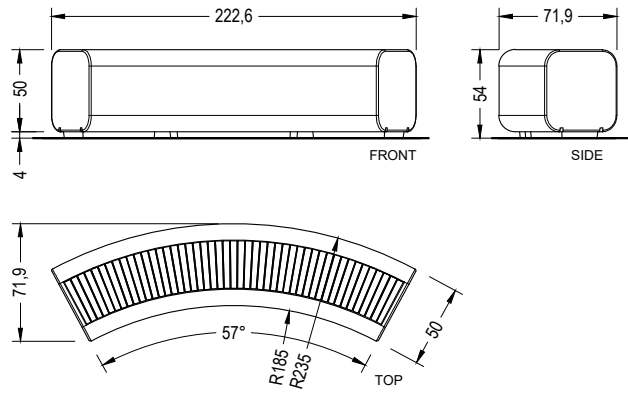

Serp R185 LED

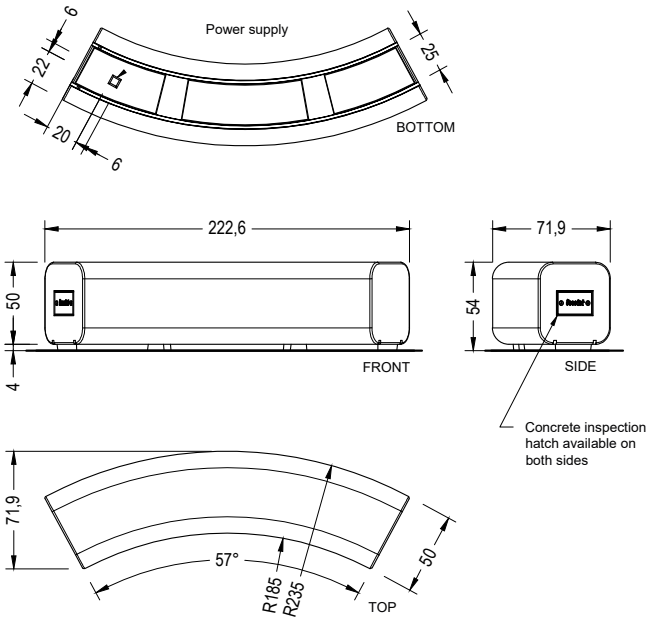

Serp Comfort R185 LED

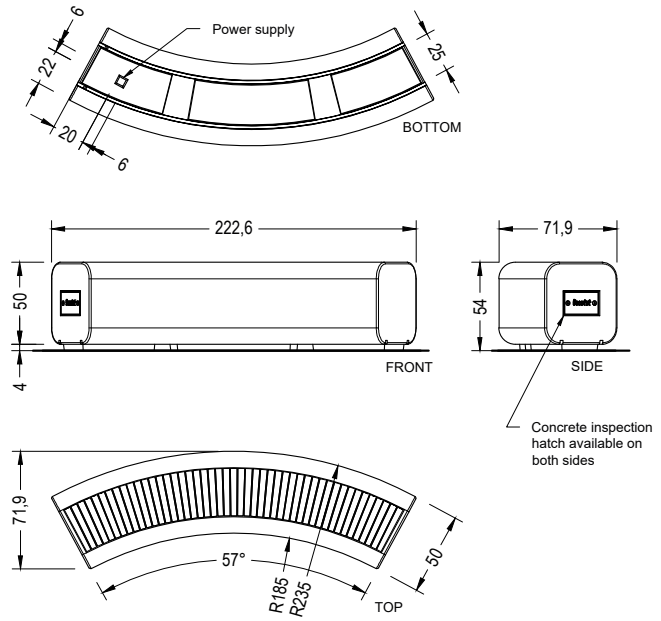

1.3 Geometry Serp R400

Serp R400

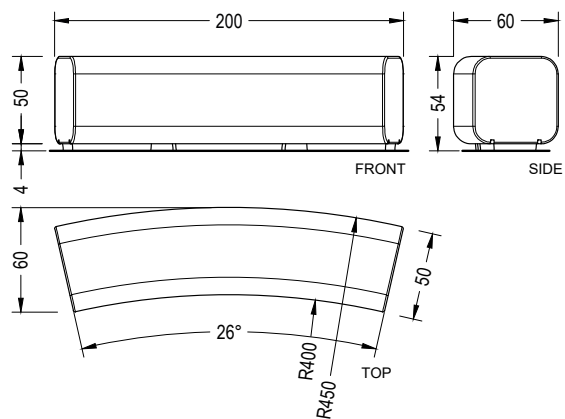

Serp Comfort R400

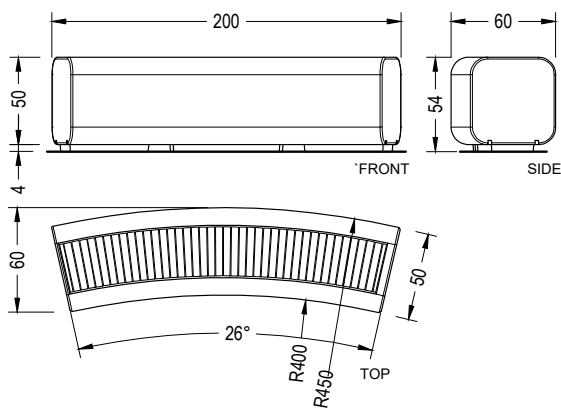

Serp R400 LED

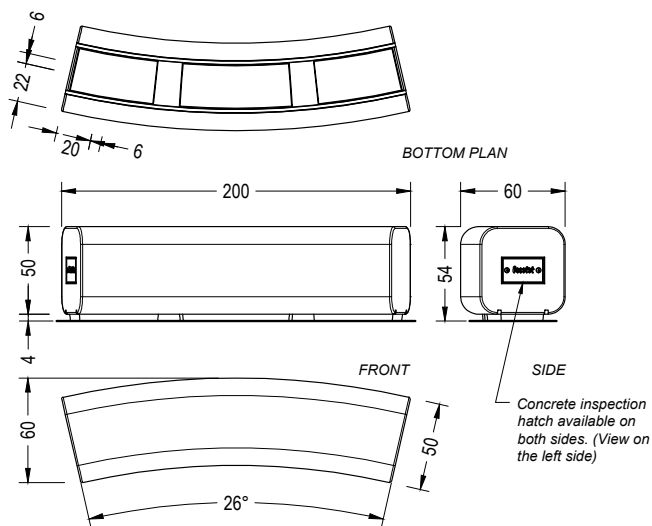

Serp Comfort R400 LED

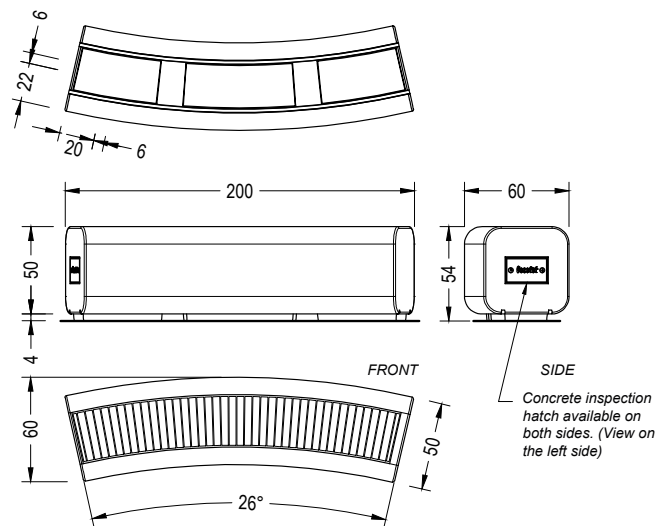

1.3 Geometry Serp R1185

Serp R1185

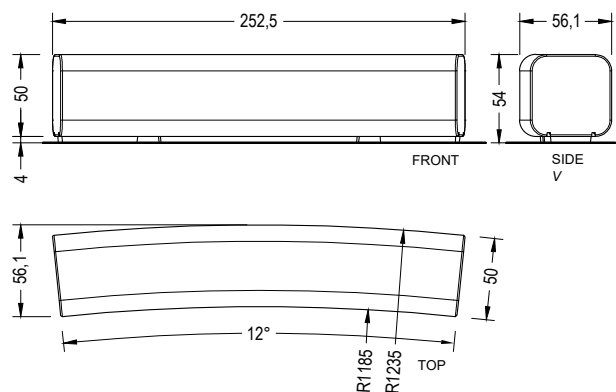

Serp Comfort R1185

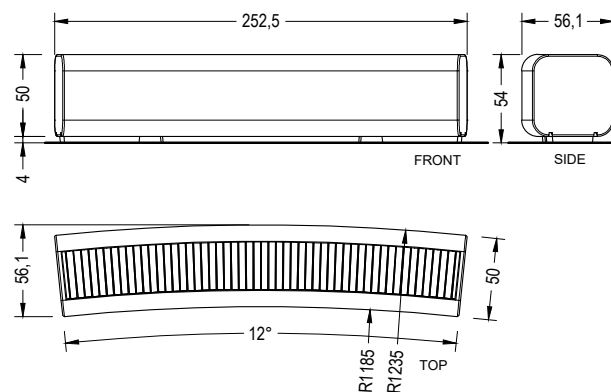

Serp R1185 LED

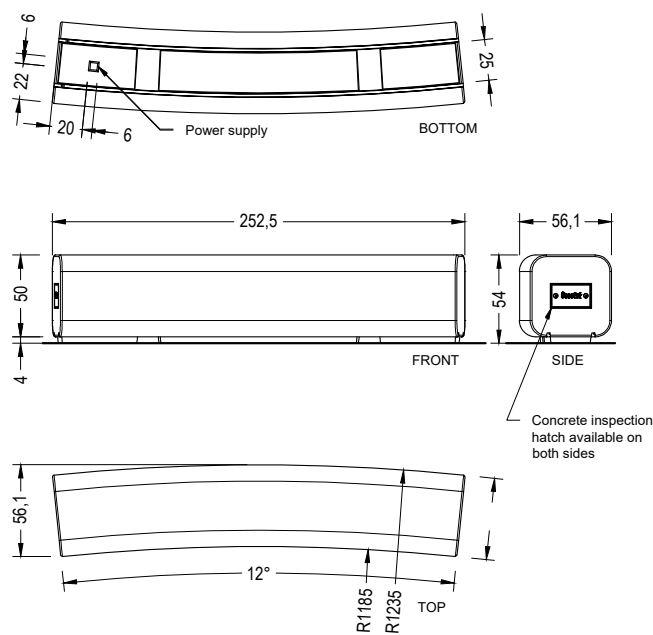

Serp Comfort R1185 LED

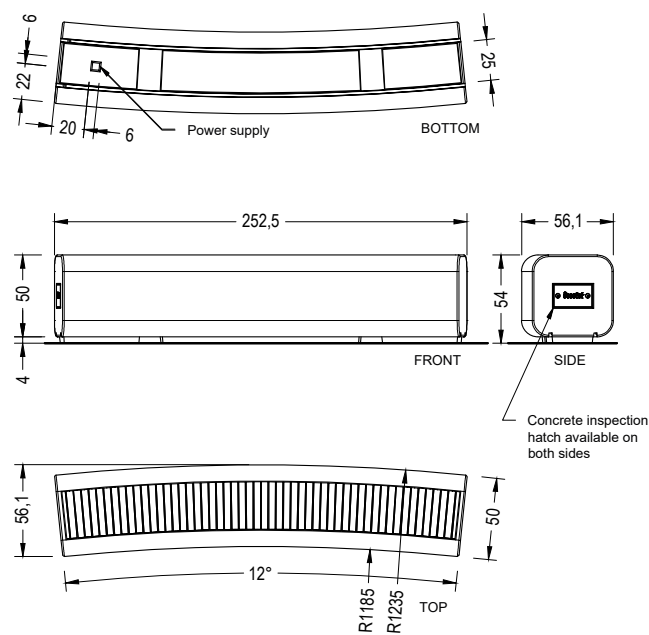

Serp R1915

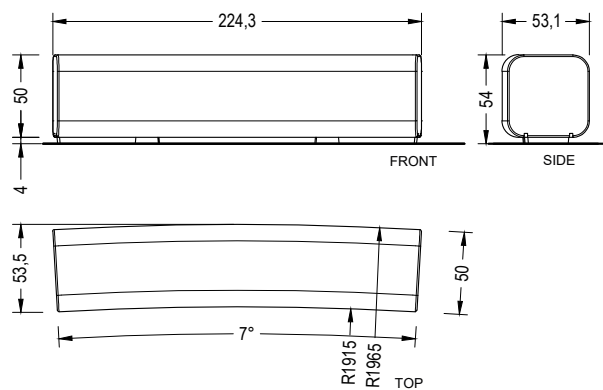

Serp Comfort R1915

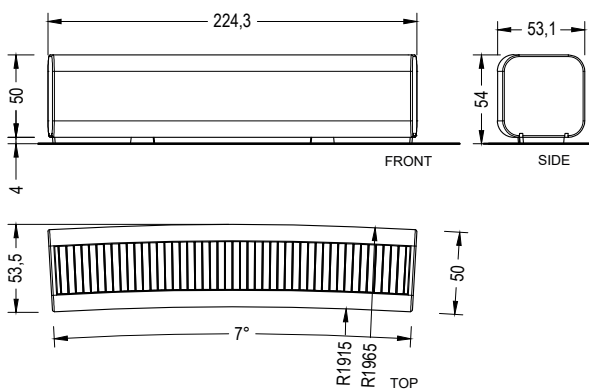

Serp R1915 LED

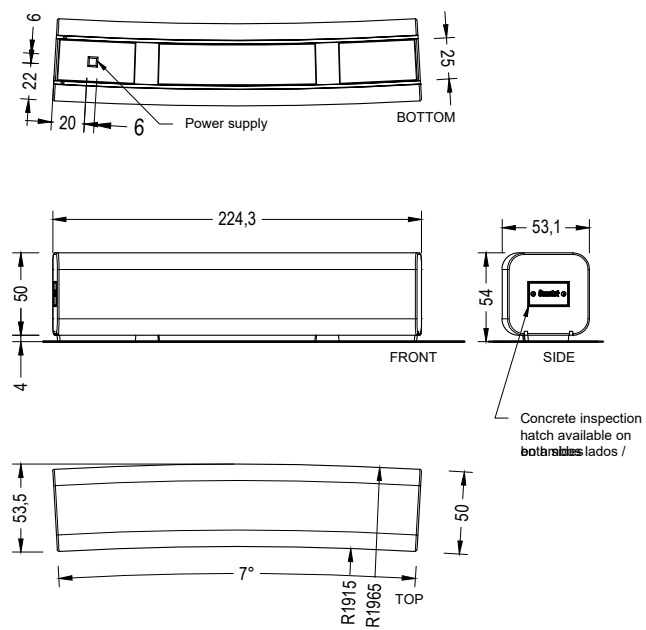

Serp Comfort R1915 LED

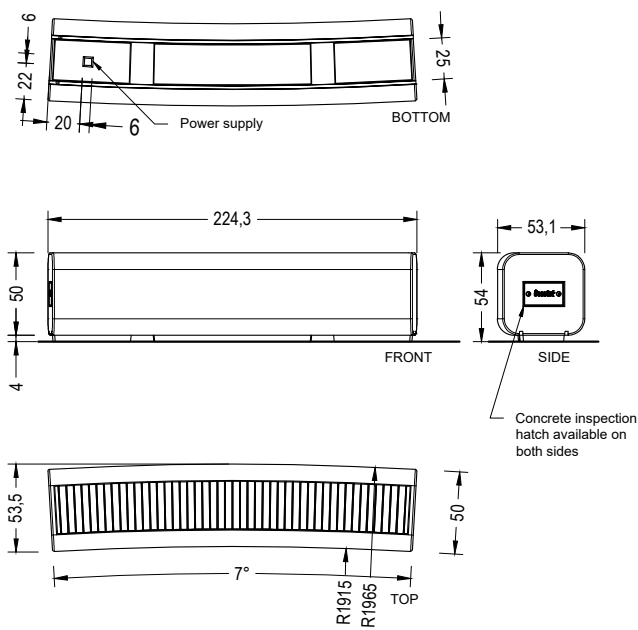

Concrete inspection hatch available on both sides /

Concrete inspection hatch available on both sides

1.3 Geometry Serp Recto

Serp Recto

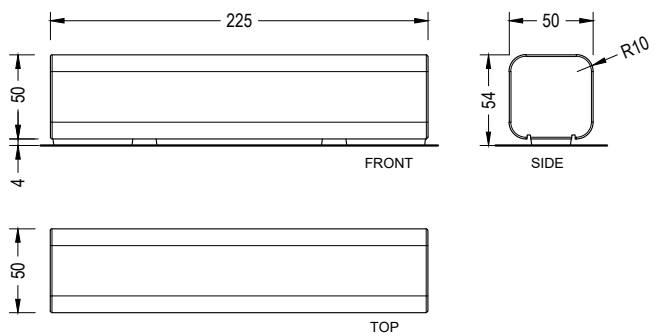

Serp Comfort Recto

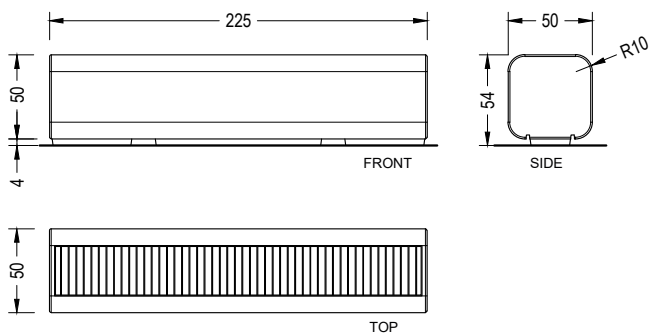

Serp Recto LED

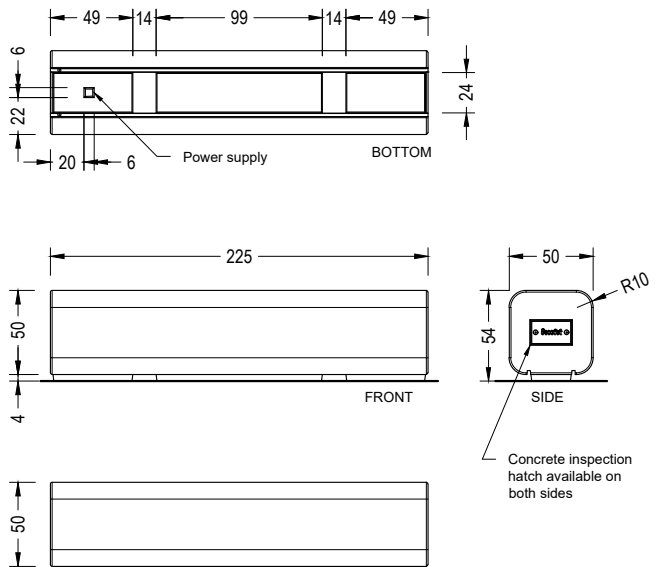

Serp Comfort Recto LED

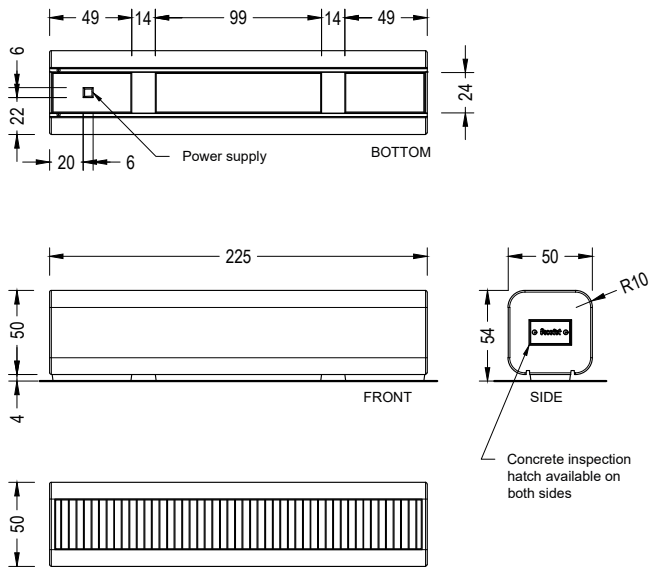

1.3 Geometry Serp Backrest R600 / Recto

Serp Backrest R600

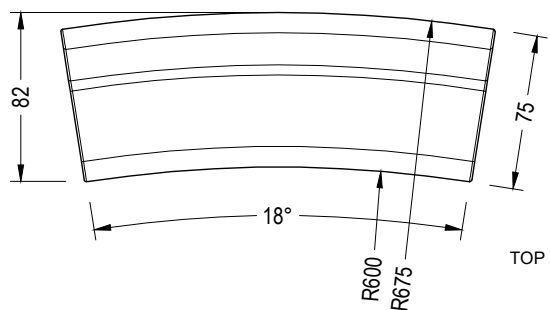
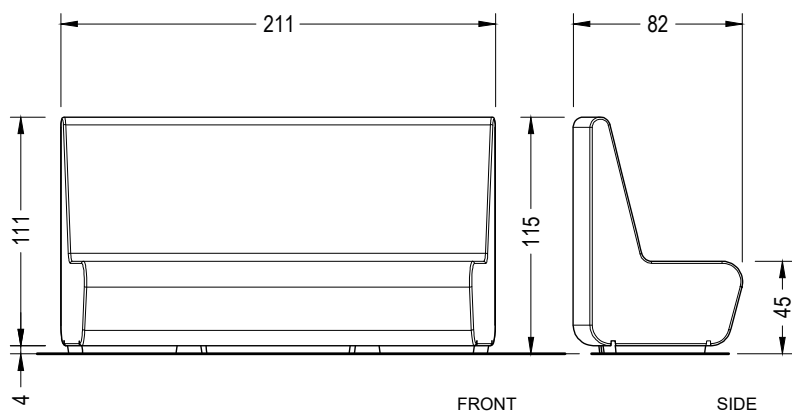

Serp Backrest Recto

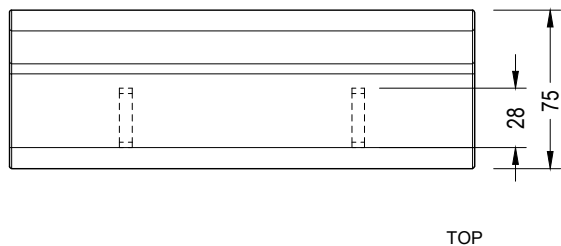
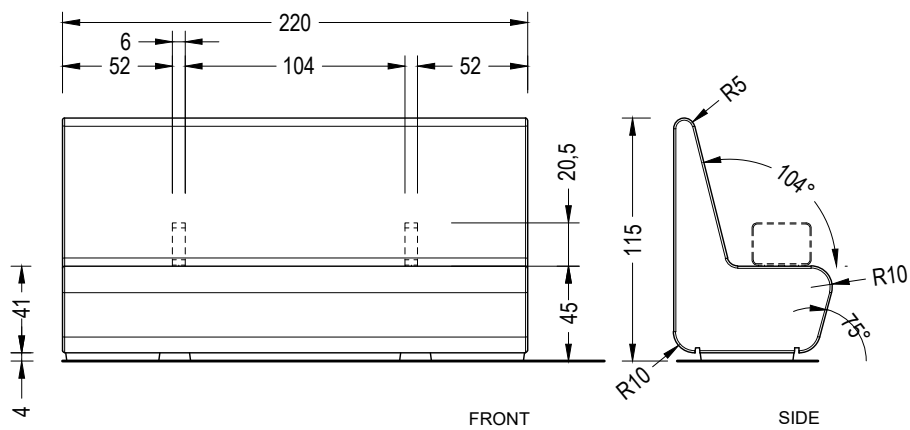

Serp R600 with backrest left

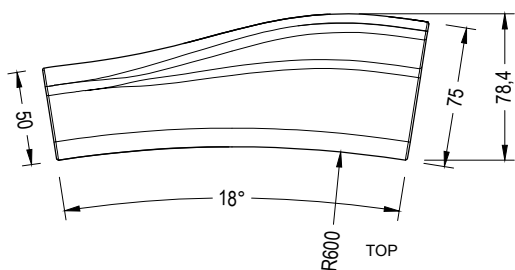
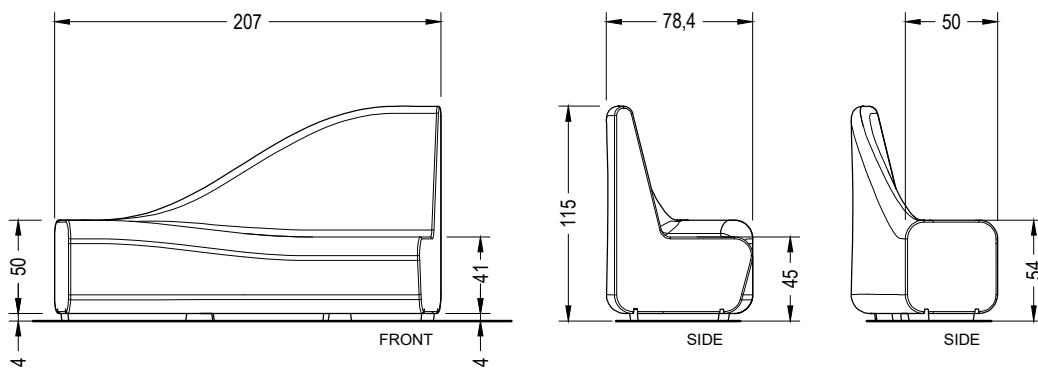

Serp R600 with backrest right

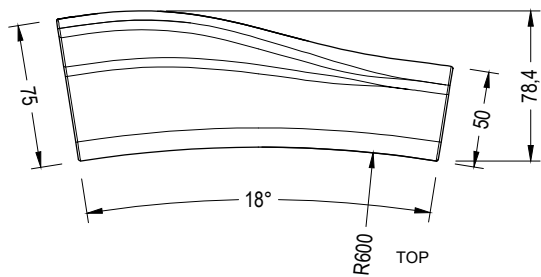
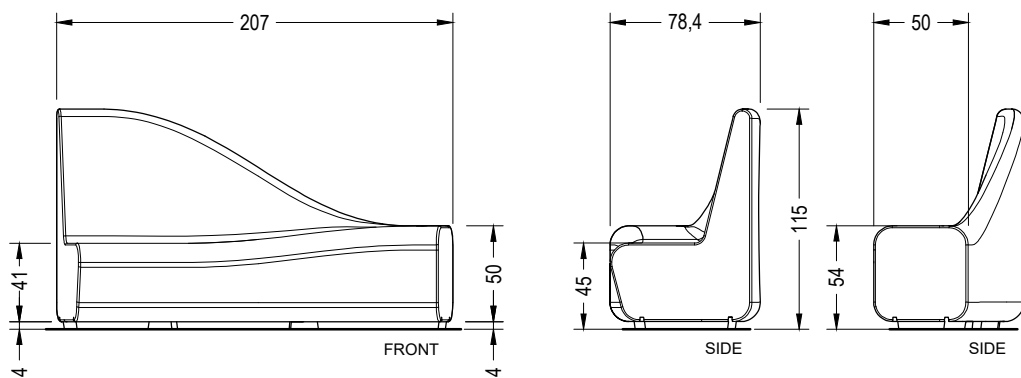

1.3 Geometry Serp Losa

Serp Transition Backless Bench - Losa

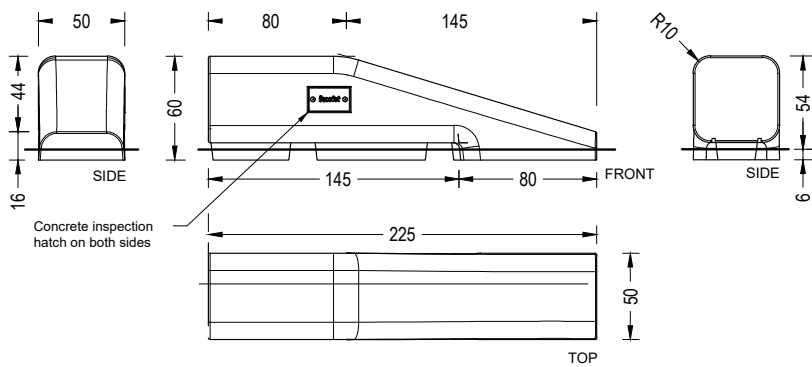

Losa Serp Recto 150

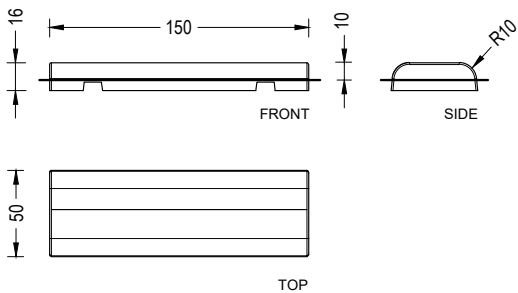

Losa Serp Curva R150 - 60°

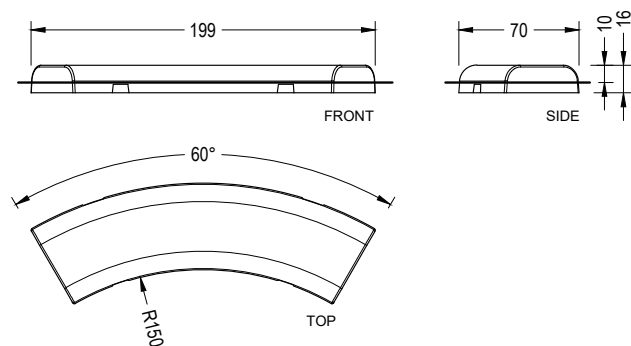

Losa Serp Curva R150 - 45°

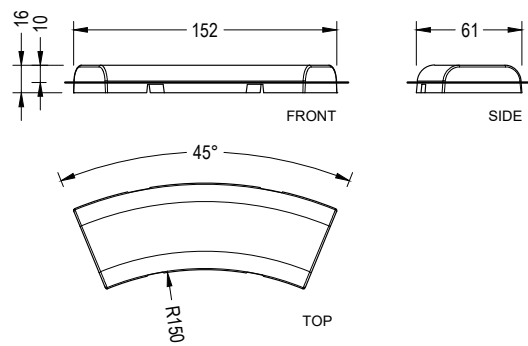

SERP



Escofet
by Molins[®]

1.4 Lighting

LED		Driver Vossloh or similar	
Operating voltage	24V	Voltage	220-240V
Power	8-15 W/m	Frequency	50-60Hz
Color temperature	4000K-3000K	Power factor	>0,9
Degree of protection	IP67	Degree of protection	IP67

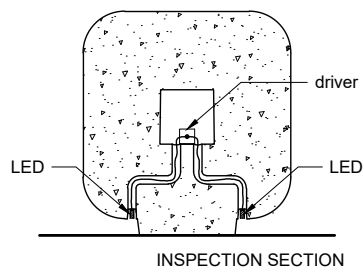

1.5 Aggregations

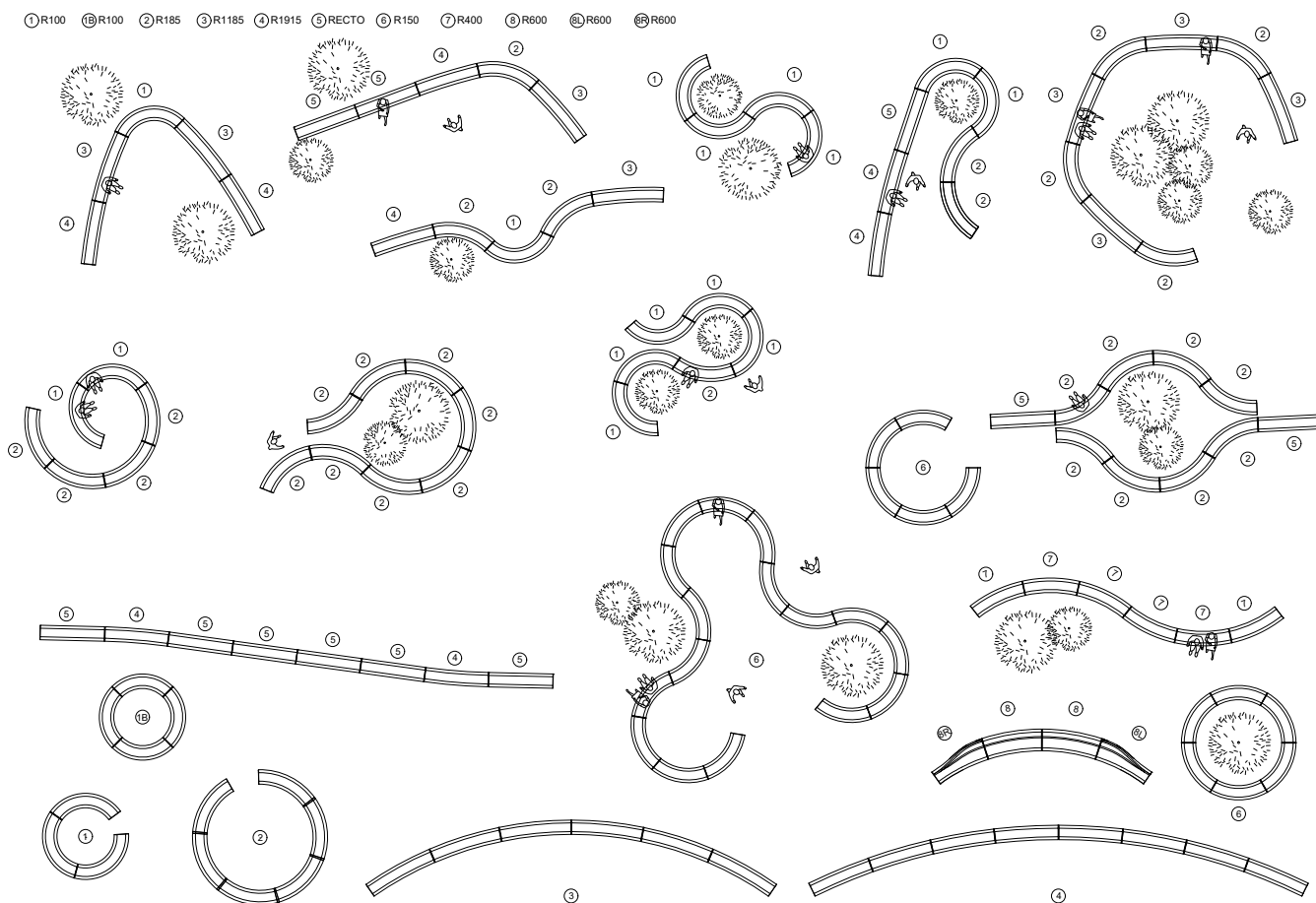

2. Steel backrest and armrest

Serp Backrest	R100 CV	R100 CX	R150 CV	R150 CX	R185 CV	R185 CX
Dimensions	243x69x72 cm	174x45x72 cm	195x36x72 cm	152x24x72 cm	218x37x72 cm	177x26x72 cm

Weight	51 kg	37 kg	39 kg	32 kg	43 kg	36 kg
---------------	-------	-------	-------	-------	-------	-------

Serp Backrest	R400 CV	R400 CX	R1185 CV	R1185 CX	R1915 CV	R1915 CX
Dimensions	193x22x72 cm	174x15x72 cm	245x18x72 cm	237x13x72 cm	217x15x72 cm	212x12x72 cm

Weight	38 kg	35 kg	46 kg	45 kg	42 kg	41 kg
---------------	-------	-------	-------	-------	-------	-------

Serp Backrest	Recto	Armrest
Dimensions	217x12x72 cm	6x28x21 cm

Weight	41 kg	2,5 kg
---------------	-------	--------

2.1 General features

Material	zinc plated steel	Fixing	anchored with expansion bolts
-----------------	-------------------	---------------	-------------------------------

Finish	coated finish colour textured silver
---------------	--------------------------------------

Colors

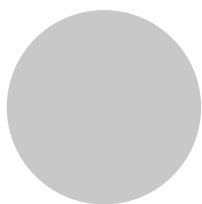

A. Textured Silver steel

2.2 Geometry

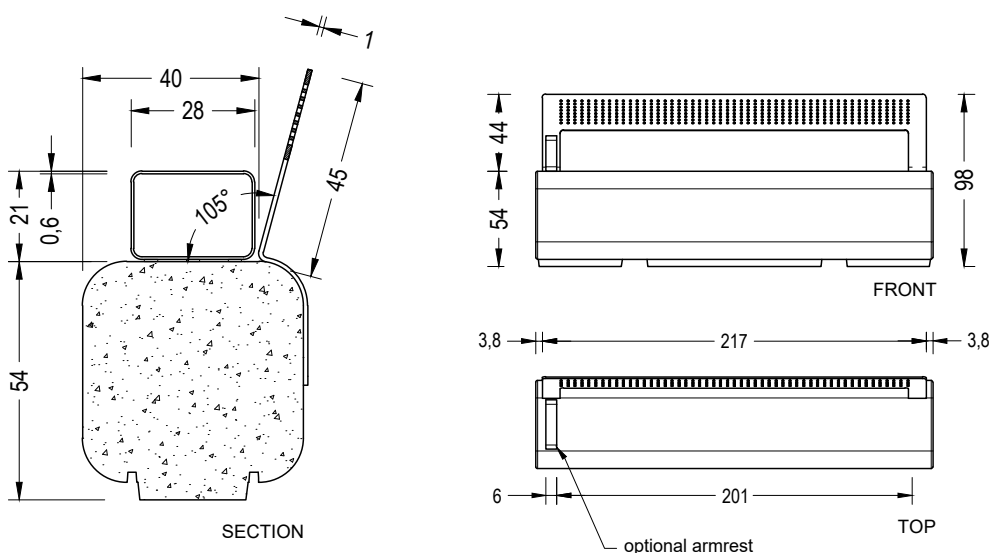

2.3 Articles

Backrest R100 CV

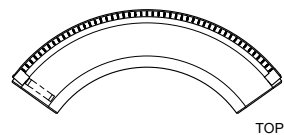
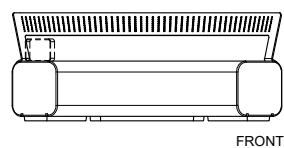

Backrest R100 CX

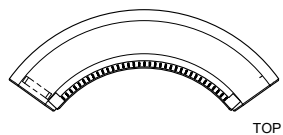
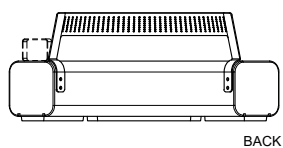

Backrest R150 CV

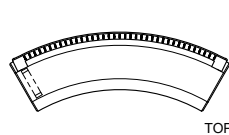
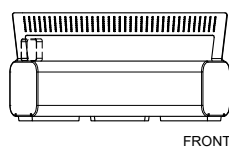

Backrest R150 CX

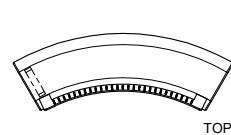
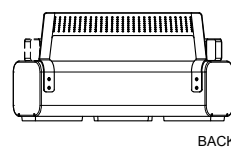

Backrest R185 CV

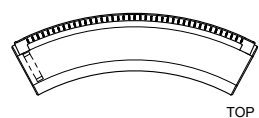
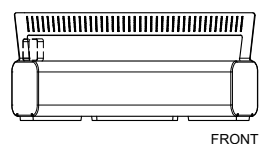

Backrest R185 CX

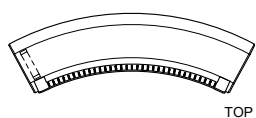
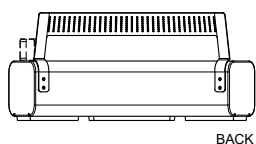

Backrest R400 CV

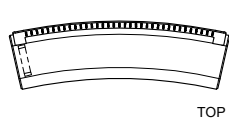
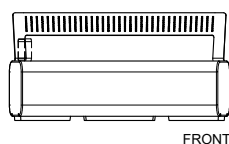

Backrest R400 CX

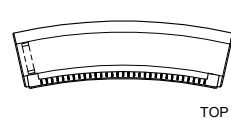
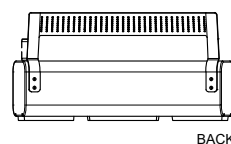

Backrest R1185 CV

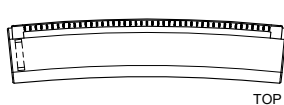
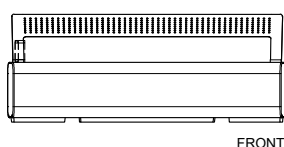

Backrest R1185 CX

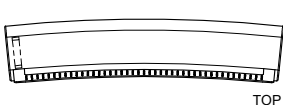
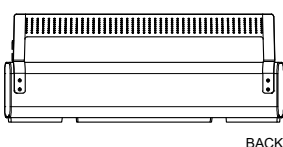

Backrest R1915 CV

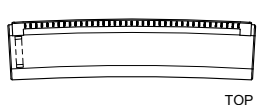
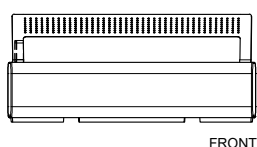

Backrest R1915 CX

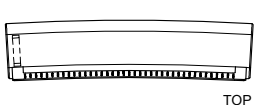
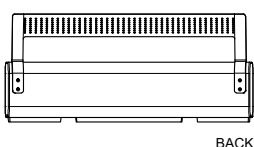

SERP



Escofet
by Molins[®]



Warranty

5 years in concrete elements.

The names, trademarks and industrial models of the products have been logged in the corresponding registers. The technical information provided by Escofet about its products can be modified without prior notice.

Escofet 1886 S.A
Head office and production

Montserrat, 162
E 08760 Martorell
Barcelona - España
T. 0034 937 737 150
F. 0034 937 737 151

info@escofet.com
www.escofet.com

Escofet
by Molins[®]

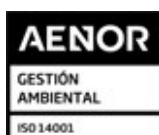

GA-2005/0072



SST-0090/2010



ER-0403/2016

